

INFINITE POWER OF IMAGINATION

Unendliche Kraft der Phantasie.
Le pouvoir infini de l'imagination.

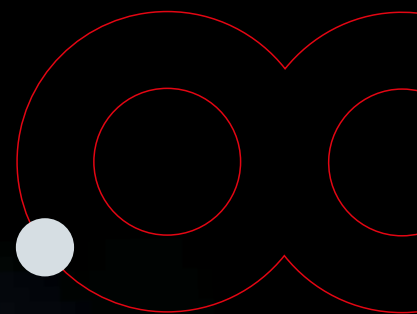

2

0

1

2



INFINITE POWER OF IMAGINATION.

Unendliche Kraft der Phantasie.
Le pouvoir infini de l'imagination.

kerrock[®]
by KOLPA





THE PORT HOUSE



40 YEARS OF TRADITION
40 JAHRE TRADITION
40 ANS DE TRADITION



PRESENT ON 44 MARKETS
ANWESEND AUF 44 MÄRKTEN
PRÉSENT DANS 44 MARCHÉS



KOLPA

The company Kolpa, d.d. Metlika is one of the leading manufacturers of bathroom equipment in the Central and Southeast Europe. Ever since it was established in 1978, it built quite a reputation based on knowledge and experience and in the process created trust in itself and in its products. The diversity of its supply meets the needs and wishes of even the pickiest individuals, while its superior products create a pleasant atmosphere where people can nourish their bodies and souls, gathering energy to take on whatever the day brings. They always look ahead. Quality is their eternal trend, committed to using only quality materials and continuously improving technological processes. The latter is the reason for the company's recent growth and expansion, even in a geographical sense. Namely, they are present in 44 countries. Kolpa has become an international company with its own manufacturing companies in Croatia, Serbia, and Russia. The company is export oriented, selling a whopping 80% of its products to tough European markets.

The Kolpa, d.d. Metlika company's vision is to stay the leading manufacturer of bathroom equipment on the Slovenian market and in countries of Southeast Europe, as well as solidifying its presence and recognizability in all European Union markets. The company is constantly evolving and creating new products, but it also wishes to become a comprehensive supplier of interior equipment for different facilities while still remaining socially responsible. Kolpa's efforts to satisfy its customers is reflected in the production of superior products for **bathroom equipment Kolpa san** and its program of **composite material Kerrock**, the technological qualities of which are a true inspiration. The company also manufactures bathtubs and showers, massage bathtubs, massage showers, and bathroom furniture. It also manufactures composite plates from which it is possible to make designs after the most original and daring ideas. One of Kolpa's major activities are engineering works under the brand **Kolpa solutions**. They take of the entire project according to the needs and wishes of its customers - from concept, planning, and design to manufacturing, installation, and after-sale activities.

KOLPA

Das Unternehmen Kolpa d.d. Metlika ist einer der führenden Hersteller von Badezimmerausstattungen in Mittel- und Südosteuropa. Seit der Gründung 1978 hat es einen starken Ruf, der auf Wissen und Erfahrung basiert und somit Vertrauen in sich selbst und seine Produkte geschaffen. Die Vielfalt der Angebote erfüllen die Bedürfnisse und Wünsche der anspruchsvollsten Kunden, qualitative Produkte schaffen eine angenehme Umgebung, wo die Menschen ihren Körper und Geist pflegen und eine Menge neuer Energie zur Bewältigung des Alltags bekommen. Ihr Blick ist die ganze Zeit nach vorne konzentriert. Qualität ist ihr ewiger Trend, weil sie die besten Materialien verwenden und ständig die technologischen Prozesse verbessern. Letzteres ist der Grund, dass das Unternehmen in letzter Zeit ein hohes Wachstum und Ausbreitung auch in geographischer Hinsicht erlebt hat. Sie sind nämlich in 44 Ländern anwesend. Kolpa ist ein internationales Unternehmen mit eigenen Produktionsunternehmen in Kroatien, Serbien und Russland geworden. Es ist ein exportorientiertes Unternehmen, die auf die anspruchsvollen europäischen Märkte sogar 80 Prozent der Produkte verkauft.

Vision des Unternehmens Kolpa d.d. Metlika ist es führender Hersteller von Badausstattungen auf dem slowenischen Markt und in den Ländern Süd-Ost-Europas zu sein, sowie mit seinen eigenen Marken die Anwesenheit und Sichtbarkeit auf allen Märkten der Europäischen Union zu bleiben. Das Unternehmen entwickelt sich ständig weiter, stellt neue Produkte her und möchte ganzheitlicher Anbieter der Innenausstattung für verschiedene Einrichtungen werden und dabei die gesellschaftliche Verantwortung behalten. Das Unternehmen Kolpa strebt nach Kundenzufriedenheit, was bei der Herstellung von qualitativ hochwertigen Produkten für **Badezimmerausstattung Kolpa san** und **Kompositmaterial Kerrock**, die durch ihre außergewöhnlich technologischen Eigenschaften begeistern, ausgedrückt wird. Das Unternehmen beschäftigt sich mit der Herstellung von Badewannen- und Duschkabinen sowie Kabinen, Massagebadewannen, Massagekabinen, Badezimmermöbeln. Es stellt auch Verbundplatten her, mit denen die Endprodukte nach den originellsten und gewagtesten Ideen geformt werden können. Eine der bedeutenden Tätigkeiten des Unternehmens Kolpa ist auch die Durchführung von Ingenieurarbeiten, hinter denen das Markenzeichen **Kolpa solutions** steht. Je nach den Bedürfnissen und Wünschen der Kunden wird für das gesamte Projekt gesorgt – vom Ideenentwurf, Planung und Design bis zur Fertigung und Montage sowie Dienstleistungen nach dem Verkauf.

KOLPA

L'entreprise Kolpa, d.d. Metlika est l'un des principaux fabricants d'équipements de salle de bains en Europe centrale et du Sud - Est. Depuis sa fondation en 1978, l'entreprise a acquis une solide réputation fondée sur ses connaissances et son expérience, créant ainsi la confiance en elle-même et dans ses produits. La diversité de l'offre répond aux besoins et aux désirs des individus les plus exigeants, et ses produits haut de gamme créent un environnement agréable où les gens soignent le corps et l'esprit pour rétablir l'énergie pour faire face à la vie quotidienne. La réflexion de l'entreprise est toujours orientée dans l'avenir. Sa préoccupation permanente c'est la qualité, d'où sa persévérance d'utiliser les meilleurs matériaux et d'améliorer constamment les processus technologiques. Ces derniers sont la raison pour laquelle l'entreprise a connu une forte croissance et élargissement aussi en termes géographiques ; ceci est confirmé par leur présence dans 44 pays. Aujourd'hui, Kolpa est une société avec ses propres entreprises de production en Croatie, en Serbie et en Russie. La société est orientée vers l'exportation et vend jusqu'à 80% de ses produits sur les marchés européens exigeants.

La vision de l'entreprise Kolpa d.d. Metlika est de rester le fabricant leader de l'équipement de salle de bains dans le marché slovène et dans les pays de l'Europe Sud - Est et d'affirmer sa présence et sa visibilité dans tous les marchés de l'Union européenne. L'entreprise est en constante évolution en créant nouveaux produits et veut devenir l'offrant complet d'aménagements intérieurs pour diverses constructions, tout en maintenant la responsabilité sociale. Les efforts de l'entreprise Kolpa pour la satisfaction des clients se reflètent dans la production des produits haute qualité pour les équipements de **salle de bains Kolpa san** et dans le programme des **matériaux composites Kerrock** qui impressionnent par leurs extraordinaires propriétés technologiques. L'entreprise produit les baignoires et baignoires et cabines de douche, baignoires de massage, cabines de massage et les meubles de salle de bains. Elle s'occupe également de la production des panneaux composites qui permettent la formation des produits finis selon les idées les plus originelles et audacieuses. L'une des activités importantes de l'entreprise Kolpa est également la réalisation de travaux d'ingénierie basée sur la marque **Kolpa solutions**. En fonction des souhaits et des besoins du client, l'entreprise prend en charge l'ensemble du projet – dès la conception, projection et design jusqu'à la production, l'assemblage et l'après-vente.

PRESENT ON THE MARKET / ANWESENHEIT AUF DEM MARKT / PRÉSENT SUR LE MARCHÉ

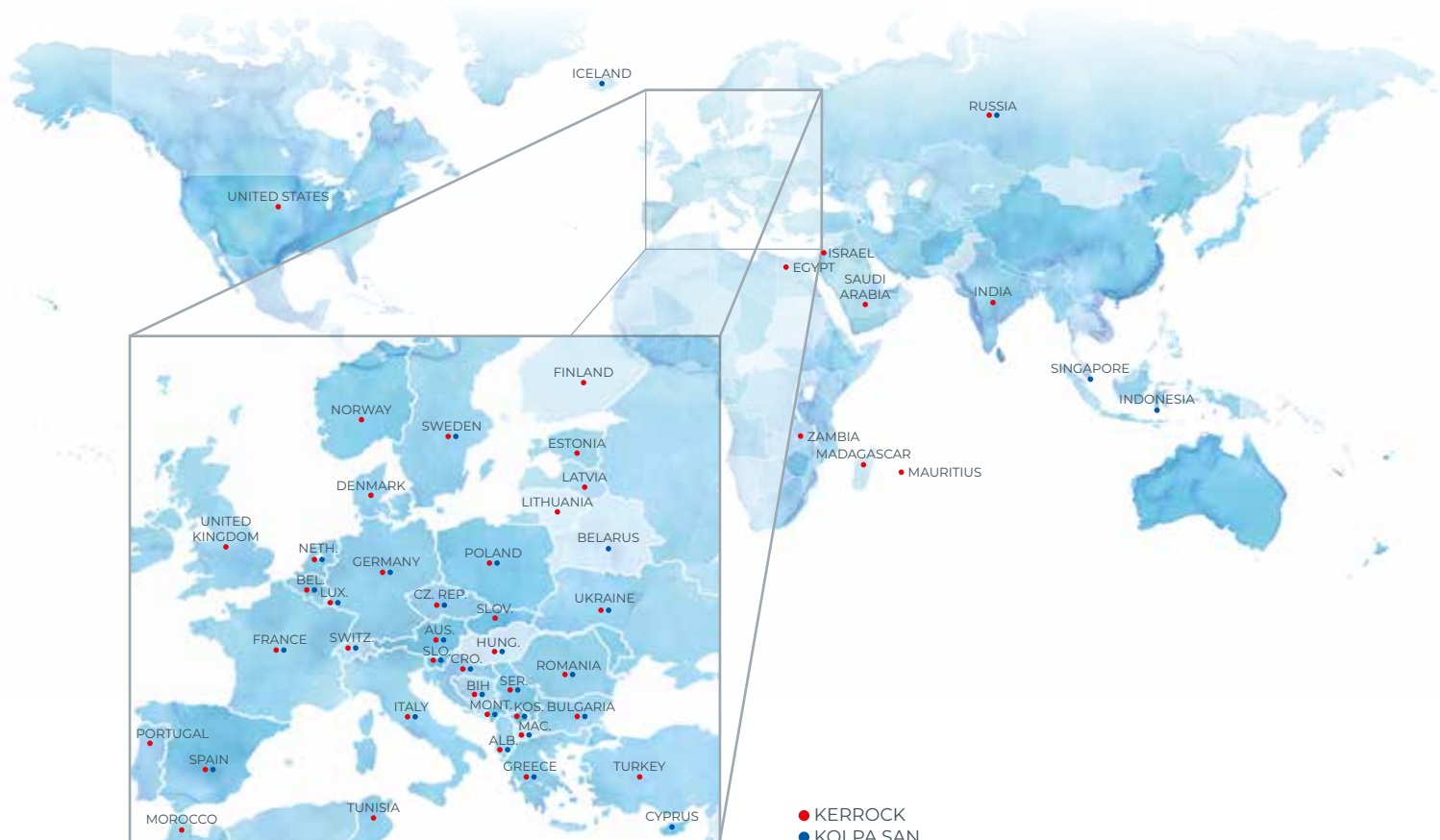

KERROCK GETS INTRODUCED. WITH EXPERIENCE.

PLEASURE OF THE TOUCH

Look of stone, pleasant and warm to the touch. Attractive and inviting surface structure. Touch it and see how nice it feels.

MECHANICAL RESISTANCE, RESISTANCE TO CHEMICALS

Surface structure designed to limit the mechanical damage and so to maintain its like-new-appearance for long. Various food stains can easily be removed. Kerrock makes ravages of time invisible.

CLIMATIC AND HEAT RESISTANCE

Solid and remarkably homogenous this material expresses stability, robustness and prevents cracking. It is resistant to hot objects and flame-retardant. Insensitive to external and internal climatic conditions. Perfectly non-porous, so absolutely water and moisture resistant.

ANTIBACTERIAL AND HEALTH-FRIENDLY

In addition to the original Kerrock you can opt for an innovative material called Kerrock plus, featuring an antibacterial substance fully integrated in its overall structure. At the touch bacteria are immediately eradicated and their further development continuously prevented.



KERROCK STELLT SICH VOR. MIT ERFAHRUNG.

FÜHLT SICH ANGENEHM AN

Sieht aus wie Stein, fühlt sich angenehm an und wirkt warm. Attraktive und ansprechende Oberflächenstruktur. Überzeugen Sie sich selbst, wie angenehm Kerrock auf Berührung ist.

MECHANISCHE FESTIGKEIT, BESTÄNDIGKEIT GEGEN CHEMIKALIEN

Die Oberflächenstruktur ist so entworfen, das mögliche mechanische Schäden begrenzt bleiben, so dass seine Optik wie neu erhalten bleibt. Verschiedene Lebensmittelflecken können ganz einfach entfernt werden. Kerrock trotz dem Zahn der Zeit.

KLIMA- UND HITZEBESTÄNDIGKEIT

Dieses massive und bemerkenswert homogene Material beeindruckt mit Stabilität, Robustheit und verhindert Rissbildung. Beständig gegen heiße Gegenstände und selbstauslöschend. Unempfindlich gegenüber äußeren und inneren klimatischen Bedingungen. Völlig porenfrei und damit absolut wasser- und feuchtigkeitsfest.

ANTIBAKTERIELL UND GESUNDHEITSFREUNDLICH

Zusätzlich zu Original-Kerrock können Sie ein innovatives Material namens Kerrock Plus mit einer, in die Gesamtstruktur völlig integrierten, antibakteriellen Substanz wählen. Beim Kontakt werden Bakterien sofort beseitigt und ihre Entwicklung wird kontinuierlich verhindert.



KERROCK SE PRÉSENTE. TENTEZ L'EXPÉRIENCE.

AGRÉABLE AU TOUCHER

Bien qu'il rappelle la pierre par son aspect, il est agréable et chaleureux au toucher. Sa surface est attractive et plaisante. Une impression agréable se dégage à son toucher.



RÉSISTANT AUX CHOCS, RÉSISTANT AUX PRODUITS CHIMIQUES

Sa surface est résistante, elle permet de limiter les détériorations et de conserver longtemps un bel aspect lisse. Les aliments et les produits chimiques ne le tâchent pas. Les ravages du temps ne laissent pas de trace sur les produits Kerrock.

RÉSISTANCE CLIMATIQUE ET THERMIQUE

Solide et extrêmement homogène, ce matériau exprime la force et la robustesse et prévient la formation de fissurations. Il est résistant à la chaleur et ignifuge. Il est insensible aux conditions climatiques extérieures et intérieures. Sa non porosité rend sa surface complètement résistante à l'eau et aux effets de l'humidité.



ANTIBACTÉRIEN ET RESPECTUEUX DE LA SANTÉ

En plus du matériel Kerrock classique, nous vous proposons également un matériau innovant Kerrock Plus avec un agent antibactérien intégré dans sa structure globale. Au toucher, sa structure détruit les bactéries et empêche de manière continue leur développement.

KERROCK CHARACTERISTICS: KERROCK - EIGENSCHAFTEN: PROPRIÉTÉS DE KERROCK :



- >> non-porous / porenfrei / non poreux
- >> resistant to mechanical impact / mechanisch beständig / résistant aux chocs
- >> resistant to chemicals / chemisch beständig / résistant aux produits chimiques
- >> resistant to heat / hitzebeständig / résistant à la chaleur
- >> pleasant to the touch / angenehm zu berühren / agréable au toucher

MAIN ADVANTAGES FOR YOUR BUSINESS HAUPTVORTEILE FÜR IHR GESCHÄFT AVANTAGES PROFESSIONNELS



Kerrock business flexibility
Kerrock flexible Anpassung an Kundenwünsche
Kerrock flexibilité professionnelle



Kerrock consulting
Kerrock Beratung
Kerrock consultation



Kerrock technical support
Kerrock technischer Support
Kerrock support technique



Kerrock training
Kerrock Ausbildung
Kerrock formation



Kerrock, made in Europe
Kerrock, made in Europe
Kerrock, fabriqué en Europe

KERROCK PRODUCTION – NEW DIMENSION OF FLEXIBILITY.

KERROCK PRODUKTION - EINE NEUE DIMENSION DER FLEXIBILITÄT.

FABRICATION KERROCK - NOUVELLE DIMENSION DE LA FLEXIBILITÉ

Tell us your requirements; we adapt: / Unser Produktionsprozess kann auf Ihre Bedürfnisse wie folgt zugeschnitten werden: / Lors du processus de fabrication, nous pouvons nous adapter à vos besoins :

- >> Kerrock sheets; width: 500 – 1350mm / Kerrock-Platten - Breite: 500 – 1350 mm / largeur des panneaux Kerrock : 500 – 1350 mm
- >> Kerrock sheets; thickness: 3 – 27mm / Kerrock-Platten - Dicke: 3 – 27 mm / épaisseur des panneaux Kerrock : 3 – 27 mm
- >> any RAL or other colour can be developed within a short time (two-week period) / jede RAL- oder andere Farbe kann in sehr kurzer Zeit (zwei Wochen) entwickelt werden / toutes les couleurs RAL ou autres couleurs peuvent être développées dans un délai court
- >> colour hues can even be developed for small quantities / Farbtöne werden auch für kleine Mengen entwickelt / nous développons également des couleurs à votre image en petite quantité
- >> own production of antibacterial Kerrock / Produktion von antibakteriellem Kerrock / fabrication du Kerrock antibactérien
- >> own production of UV-resistant Kerrock for exterior use / Produktion von UV-stabilem Kerrock für Außenoberflächen / fabrication du Kerrock résistant aux rayons UV conçu pour les applications extérieures

92 STANDARD KERROCK COLOUR HUES AVAILABLE



92 KERROCK SONDERFARBEN ERHÄLTlich
UNE GAMME DE 92 COULEURS KERROCK STANDARDS

KERROCK IS ALSO USED FOR THE FOLLOWING
APPLICATIONS:

KERROCK WIRD AUCH IN DEN FOLGENDEN
BEREICHEN VERWENDET:

LES DIFFÉRENTES UTILISATIONS ET APPLICATIONS
DE KERROCK :

- >> kitchen / Küche / Kerrock en cuisine
- >> bathroom / Bad / Kerrock en salle de bains
- >> hotel, restaurant / Hotel, Restaurant / Kerrock dans L'hôtellerie et la restauration
- >> laboratory and hospital / Labor und Krankenhaus / Kerrock dans les laboratoires et les hôpitaux
- >> office / Büro / Kerrock dans les établissements commerciaux
- >> school, kindergarten / Schule, Kindergarten / Kerrock dans les écoles et les jardins d'enfants
- >> boat, motorhome... / Boot, Wohnmobil... / Kerrock dans le nautisme et les véhicules de loisirs...

EASE OF CARE PFLEGELEICHTIGKEIT FACILITE DE NETTOYAGE

- >> simple to clean and maintain / einfach zu reinigen und unterhalten / nettoyage et entretien faciles
- >> ordinary agents / gewöhnliche Reinigungsmittel / produits de nettoyage courants
- >> fine abrasives / feine Schleifmittel / produits abrasifs fins
- >> grinding and polishing / Schleifen und Polieren / ponçage et polissage



*Live your life.
In colours!
Leben Sie Ihr Leben in
Farbe!
Rayonnez.
En couleurs !*

DO NOT WORRY. WE ARE HERE TO RESPOND TO ALL YOUR CHALLENGES.

Kolpa's company tradition dates back to 1978. Mainly thanks to its experience, continuous improvement and innovative approaches, the company has built a strong global reputation to date. Kolpa is focused on addressing customers' challenges by producing top quality products. Products that inspire by their aesthetics and technological features. **Continuously focused on your requirements, Kolpa has created a field of confidence in the product, the partnership and the longterm success.**

KEINE SORGEN. FÜR ALLE IHRE HERAUSFORDERUNGEN HABEN WIR DIE RICHTIGE ANTWORT.

Die Geschichte der Firma Kolpa beginnt 1978. Dank der Erfahrung, kontinuierlicher Verbesserung und innovativen Ansätzen hat das Unternehmen bis heute einen guten Ruf erarbeitet. Durch die Herstellung qualitativ hochwertiger Produkte ist Kolpa ganz klar auf die Herausforderungen der Kunden konzentriert. Produkte, die durch ihre Ästhetik und zahlreiche technische Eigenschaften begeistern. **Kontinuierlich auf Ihre Anforderungen ausgerichtet hat Kolpa ein Feld von Vertrauen in das Produkt, die Partnerschaft und den langfristigen Erfolg erstellt.**



**KERROCK
PLUS**
(KERROCK FEATURING
ANTIBACTERIAL COMPOSITION)

KERROCK PLUS
(KERROCK MIT ANTIBAKTERIELLER
ZUSAMMENSETZUNG)

KERROCK PLUS
(COMPOSITION
ANTIBACTERIENNE DE
KERROCK)

SANS SOUCIS. NOUS AVONS UNE REPONSE A VOS DEFIS.

La tradition de la société Kolpa remonte à 1978. La société a bâti sa renommée à l'échelle mondiale. Elle est fondée principalement sur le savoirfaire, la recherche d'amélioration et une approche novatrice. Kolpa concentre ses efforts sur la façon de répondre aux défis de ses clients tout en fabriquant des produits de qualité supérieure. Ses produits enthousiasment par leurs propriétés esthétiques et techniques.

En se concentrant sur vos besoins, Kolpa d.d. crée un espace de confiance en nos produits, de partenariat et de réussite durable.

KERROCK PRODUCTION – NEW DIMENSION OF FLEXIBILITY

TELL US YOUR REQUIREMENTS; WE ADAPT:

- >> Kerrock sheets; width: 500 – 1350mm
- >> Kerrock sheets; thickness: 3 – 27mm
- >> any RAL or other colour can be developed within a short time (two-week period)
- >> colour hues can even be developed for small quantities
- >> own adhesives manufacturing and tinting
- >> own production of antibacterial Kerrock
- >> own production of UV-resistant Kerrock for exterior use

KERROCK PRODUKTION – EINE NEUE DIMENSION DER FLEXIBILITÄT

UNSER PRODUKTIONSPROZESS KANN AUF IHRE BEDÜRFNISSE WIE FOLGT ZUGESCHNITTEN WERDEN:

- >> Kerrock-Plattenbreite von 500 bis 1350 mm
- >> Kerrock-Plattendicke von 3 bis 27 mm
- >> Jede RAL- oder andere Farbe kann in sehr kurzer Zeit (zwei Wochen) entwickelt werden
- >> Farbtöne werden auch für die kleinsten Mengen entwickelt
- >> eigene Produktion und Abtönen von Klebstoffen
- >> Produktion von antibakteriellem Kerrock
- >> Produktion von UV-stabilem Kerrock für Außenoberflächen

FABRICATION KERROCK – NOUVELLES DIMENSION DE LA FLEXIBILITE

LORS DU PROCESSUS DE FABRICATION, NOUS POUVONS NOUS ADAPTER A VOS BESOINS :

- >> largeur des panneaux Kerrock : 500 – 1350 mm
- >> épaisseur des panneaux Kerrock : 3 – 27 mm
- >> nous développons la couleur à votre image
- >> nous développons également des couleurs à votre image
- >> fabrication des adhésifs
- >> fabrication du Kerrock antibactérien
- >> fabrication du Kerrock résistant aux rayons UV conçu pour les applications extérieures

INFINITY.

POWER. IMAGINATION.

Compatibility of aluminium hydroxide and a polymer binder based on acrylic. Composite, smooth, non-porous and homogeneous. Creator of aesthetics and functionality. Making great impression by any building in or out.

Its time has arrived. Time for infinite power of imagination.

UNDENDLICHKEIT. KRAFT. PHANTASIE.

Verbundwerkstoff aus Aluminiumhydroxid und einem Acryl. Glatt, nicht-porös und homogen. So vereinen Sie Ästhetik und Funktionalität und schaffen einen guten Eindruck für jedes Gebäude und jeden Raum.

Die Zeit ist angekommen. Unendliche Kraft der Phantasie.

*Some see it as
the material of the future;
others call it simply -
revolution.*

*Einige sehen es als das Material der
Zukunft. Andere nennen es einfach -
Revolution.*

*Certains l'appellent le matériau
de l'avenir, c'est tout simplement
- une révolution.*



L'INFINI POUVOIR DE L'IMAGINATION.

Conjugaison parfaite de l'hydroxyde d'aluminium et d'un polymère acrylique. Composite, lisse, non poreux et homogène. Le créateur de l'esthétique et du fonctionnel. Valorise les bâtiments et leurs aménagements.

Aujourd'hui, son ère commence. L'ère de l'infini pouvoir de l'imagination.

Enjoy every moment; love each of your days. Life in colours of nature throughout the blurred boundaries between the indoor and the outdoor. Staying in the intersection between playfulness with sensuality and eternal beauty.

Power of Stone and Warmth of Sun. Get to know it; feel its toughness and its pleasant touch.

Genießen Sie jeden Augenblick, lieben Sie jeden Ihrer Tage. Schnittstelle zwischen spielerischer Sinnlichkeit und ewiger Schönheit.

Härte des Steins und Wärme der Sonne. Trotz robuster Oberfläche verfügt Kerrock über eine angenehm warme Haptik.

Profitez de chaque instant, aimez chaque jour. Vivez au couleurs de la nature, traversez la frontière floue de l'extérieur et de l'intérieur. Restez à l'intersection entre le ludique, la sensualité et la beauté éternelle.

La force de la pierre et la chaleur du soleil. Faites connaissance, tentez l'expérience de sa force et le plaisir de son toucher.

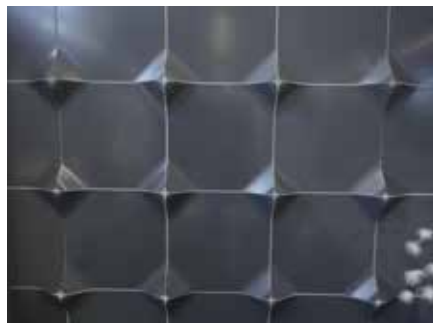

VERSATILE. KERROCK.

By **implementing Kerrock** you make the lines between the indoor and the outdoor get blurred. With its organic design it melts with the environment, raising the overall harmony. Through its quite astonishing design options and a wide range of colours it can assume countless forms of occurrence. Kerrock. Truly versatile.



VIELSEITIG. KERROCK.

Durch den **Einsatz von Kerrock** verschwinden die Grenzen zwischen Innen und Außen. Sein organisches Design verschmilzt mit der Umgebung und steigert die Harmonie. Durch seine erstaunlich vielfältigen Gestaltungsmöglichkeiten und eine breite Palette von Farben kann es unzählige Formen annehmen. Kerrock. Wahrhaft vielseitig.



UNIVERSEL. KERROCK.

En **mettant en oeuvre du Kerrock**, nous brisons la limite entre l'espace extérieur et intérieur. Grâce à son design organique, il se mélange à l'environnement, il souligne l'harmonie naturelle. Grâce à son incroyable capacité conceptuelle et sa large gamme de couleurs, il peut prendre toutes les formes. Kerrock. Totalement universel.



In particular, Kerrock is distinguished by its durability, design options, environmental friendliness, wide range of applications, easy cleaning and processing.

Prof. dr. Milan Šernek / Faculty of Biotechnology

Insbesondere zeichnet sich Kerrock durch seine Langlebigkeit, Gestaltungsmöglichkeiten, Umweltfreundlichkeit, breite Palette von Anwendungen, einfache Reinigung und Verarbeitung aus.

Prof. dr. Milan Šernek / Fakultät für Biotechnologie

Les principales propriétés de Kerrock sont durabilité, créativité, respect de l'environnement, polyvalence, façonnage et entretien faciles.

Professeur Dr. Milan Šernek / Faculté biotechnique

INTERIOR. KERROCK.

Imagine a freely breathing and freshness-radiating space. Inspired by nature and imagination, it makes through its bold design solutions the space come to life and become pleasant to stay. Interior. Kerrock.



INNEN. KERROCK.

Stellen Sie sich einen Raum vor, der Freiheit und Frische ausstrahlt. Inspiriert durch die Natur und die Phantasie, die durch außergewöhnliche Designlösungen den Raum zum Leben bringen und für einen sehr angenehmen Aufenthalt sorgen. **Innen.** Kerrock.

INTERIEUR. KERROCK.

Imaginez un espace qui dégage une sensation de liberté et de fraîcheur. Inspirez par la nature et l'imagination, grâce à ses solutions de design audacieux. L'espace s'anime et devient très agréable à vivre. **Intérieur.** Kerrock.



Bathroom. No longer limited to just a place of personal hygiene. Bathroom has become art. Functional art. And Kerrock the artist with experience.

Badezimmer. Nicht länger nur auf Körperpflege beschränkt. Das Bad hat sich zur Kunst entwickelt. Funktionale Kunst. Und Kerrock zum Künstler mit Erfahrung.

Salle de bains. N'est plus un simple espace pour une bonne hygiène personnelle. La salle de bains est devenue un art. Art fonctionnel. Et Kerrock est l'artiste d'expérience.





PURE
RELAXATION.
**KERROCK
IN YOUR
BATHROOM.**

REINE
ENTSPANNUNG.
**KERROCK IN
IHREM BAD.**

RELAXATION
ULTIME.
**KERROCK DANS
LA SALLE DE
BAINS.**

*Get touched by the
gentleness upon the
contact with water
moving along the Kerrock shapes.*

*Lassen Sie sich durch den angenehmen
Kontakt mit Wasser, das entlang der
Kerrock Formen fließt, berühren.*

*Que la douceur de l'eau vous
caresse en glissant sur des
formes en Kerrock.*



INFINITY OF COLOURS
UNENDLICHKEIT DER FARBEN
DES COULEURS A L'INFINI

ENJOY YOUR
MEAL.
**KERROCK IN
YOUR KITCHEN.**

GUTEN APPETIT.
**KERROCK IN
IHRER KÜCHE.**

BON APPETIT.
**KERROCK DANS
LA CUISINE.**

*Kitchen is the heart of your
home. With Kerrock it becomes
love.*

*Ihre Küche ist das Herz Ihres Hauses.
Mit Kerrock wird sie vollkommen.*

*La cuisine est le coeur de la maison.
Elle se transforme en amour grâce
au Kerrock.*

Starting with a fragrant cup of coffee and a look at the beautiful shapes of Kerrock, your day will be fine. Health-friendly, resistant to mechanical impact, and of great aesthetics. **The Kerrock Kitchen.**

Ein Tag, der mit einer herrlich duftenden Tasse Kaffee und mit dem Blick auf die schönen Formen von Kerrock anfängt, wird ein angenehmer Tag. Gesundheits- und umweltfreundlich, mechanisch fest und zeitlos.

Die Kerrock Küche.

Commencer la journée avec une tasse de café parfumé et un regard posé sur de magnifiques formes en Kerrock, c'est commencer une bonne journée. Sain et résistant aux chocs, avec une esthétique immense. **La cuisine Kerrock.**





*Kerrock, born to
exceed the
average!*

*Kerrock. Hergestellt, um den
Durchschnitt zu übertreffen!*

*Kerrock, créé pour se
surpasser!*



KERROCK

PROFESSIONAL EXCELLENCE

Customer satisfaction is what we strive for. We also appreciate the recognition granted to us by the insiders - based on expert judgment.



reddot design award
winner 2007



reddot design award
honourable mention 2010

KERROCK

PROFESSIONELLE EXZELLENZ.

Kundenzufriedenheit - das ist es, was bei uns am meisten geschätzt wird. Wir schätzen aber auch die Anerkennung, die uns durch die Insider gewährt wird - basierend auf Expertenurteil.



KERROCK

EXCELLENCE PROFESSIONNELLE.

La satisfaction de tous les utilisateurs de Kerrock, c'est notre plus grande réussite. Nous nous félicitons de la reconnaissance qui nous est accordée par les professionnels – basée sur leurs jugements d'experts.



BECAUSE YOU
ARE STANDING
OUT.

**KERROCK IN
HOTELS.**

WEIL SIE
AUFFALLEN.

**KERROCK IN
HOTELS.**

PARCE QUE
VOUS IMPOSEZ.

**KERROCK DANS
LES HÔTELS.**

*Infinite
design options.*

*Unendliche
Designmöglichkeiten.*

*Possibilités infinies de
conception.*

For hotel projects **Kerrock** composite material is largely used. It is particularly suitable for demanding and daring clients. It is available in many colours and dimensions, allowing most innovative forms to be created. It can be used without barriers and adaptation: stains or scratches make no harm. In case of damage it can easily be repaired or restored. There are no problems with maintenance or hygiene as its surface is fully non-porous and smooth. Joints are blurred and with no embossed effect.

Für Hotel-Projekte wird **Kerrock** Verbundwerkstoff weitgehend verwendet. Er ist besonders für gewagte Vorstellungen anspruchsvoller Kunden geeignet. Er ist in vielen Farben und Abmessungen erhältlich, damit auch höchstinnovative Formen erstellt werden können. Er kann ohne Barrieren und Anpassungen verwendet werden: Kratzer oder Flecken hinterlassen keine Schäden. Im Falle eines Schadens kann er leicht repariert oder wiederhergestellt werden. Es gibt keine Probleme mit der Wartung oder Hygiene, da seine Oberfläche völlig porenfrei und glatt ist. Fugen sind verwischt und ohne Prägeeffekt.

Pour les projets hôteliers, **Kerrock** tient une place importante. Il est adapté aux clients exigeants et audacieux. Ce dernier est réalisable en couleurs et tailles différentes et peut prendre les formes les plus innovantes. Il peut être utilisé sans contrainte et s'adapte facilement. Les taches ou les rayures ne peuvent l'altérer. En effet, en cas de dommages, il est facile à réparer et à rénover. L'entretien et l'hygiène ne posent aucun problème, parce que sa surface est non poreuse et lisse. Les assemblages fusionnent sans laisser de relief.

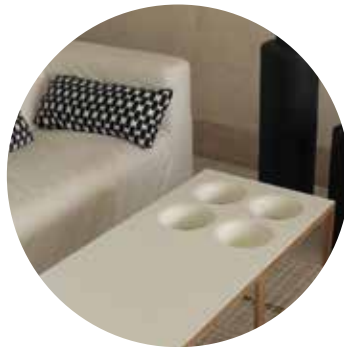

Kerrock is without any doubt the material that fully satisfies specific needs in medicine and pharmacy. It feels pleasant and warm to the touch, it is non-porous and exceptionally easy to clean and maintain.

Kerrock ist ohne Zweifel das Material, das die sehr hohen Anforderungen in der Medizin und Pharmazie vollständig erfüllt. Es fühlt sich angenehm und warm an, ist völlig porenfrei und besonders einfach zu reinigen und unterhalten.

Sans aucun doute, Kerrock est un matériau qui satisfera pleinement les besoins spécifiques dans les établissements de santé. Beau et chaleureux au toucher, non poreux et extrêmement facile à nettoyer et à entretenir.



HOW CAN WE
HELP YOU?
**KERROCK IN
MEDICINE.**

WIE KÖNNEN
WIR IHNEN
HELFEN?
**KERROCK IN
DER MEDIZIN.**

COMMENT
POUVONS-
NOUS VOUS
AIDER ?
**KERROCK EN
MÉDECINE.**

Space that
radiates *trust*.

Raum, der Vertrauen
ausstrahlt.

L'espace qui développe
la confiance.

SAY WELCOME.
WITH STYLE.
**KERROCK IN
RETAIL.**

HEISSEN SIE
WILLKOMMEN.
MIT STIL.
**KERROCK IM
EINZELHANDEL.**

DITES SOYEZ
LE BIENVENU.
AVEC DU STYLE.
**KERROCK EN
VENTE AU
DETAIL.**





*Space which calls for
good business.*

*Der Raum, der nach einem
guten Geschäft ruft.*

*Espace annonce une
Bonne affaire.*

We ensure high-quality materials, modern lines, technical perfection, and a harmony of shapes, colours, and functionality. The result is a pleasant and inspiring working environment.

Wir bieten qualitativ hochwertige Materialien, moderne Linien, technische Perfektion, Harmonie der Formen, Farben und Funktionen. Das Ergebnis ist eine angenehme und inspirierende Arbeitsumgebung.

Nous fournissons les matériaux de haute qualité, des lignes modernes, la perfection technique, l'harmonie des formes, des couleurs et de la fonctionnalité. Le résultat est un environnement de travail agréable et inspirant.



We carefully select elements and perform them thoroughly. By combining superior forms and useful qualities, we create a comfortable environment in any public space.

Sorgfältig wählen wir Elemente aus und stellen diese präzise her. Durch eine Kombination von qualitativen Formen und nützlichen Eigenschaften schaffen wir ein angenehmes Wohlbefinden in jedem öffentlichen Raum.

Nous sélectionnons soigneusement les éléments et assurons leur mise en oeuvre précise. En combinant les formes de première classe avec les fonctionnalités utiles, nous obtenons un sentiment de confort dans chaque espace public.

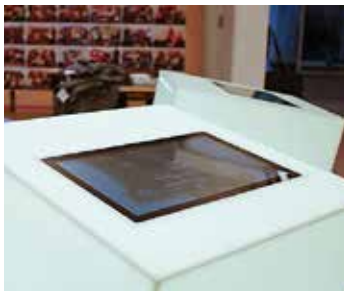

Relaxed, as if you
were at *home*.

Entspannt, als waren Sie
zuhause.

Detendu, comme a la
maison.

DISGUISE OF
MODERNITY
**KERROCK IN
PUBLIC SPACES.**

VERKLEIDUNG
DER MODERNE
**KERROCK IN
ÖFFENTLICHEN
RÄUMEN.**

APPARENCE
CONTEMPORAINE
**KERROCK
DANS LES
INSTITUTIONS
PUBLIQUES.**

A WELL
DESERVED
BREAK!
**KERROCK IN
WELLNESS.**

EINE
WOHLVERDIENTE
PAUSE!
**KERROCK IM
WELLNESS.**

DETENTE QUE
VOUS MERITEZ !
**KERROCK DANS
WELLNESS.**





*Aesthetics
in the function of space.
Ästhetik in Funktion des
Raums.
Esthétique en fonction de
l'espace.*

Space of intimacy through which your guests will be connected with the greatest jewel of nature. Through sophisticated forms water flows to the user to relax his/her body and soul.

Ein Raum von Intimität, durch welchen Ihre Gäste mit dem größten Juwel der Natur verbunden werden. Durch die ausgefeilten Formen fließt das Wasser zum Benutzer, um seine/ihre Körper und Seele zu entspannen.

L'espace d'intimité qui liera vos hôtes avec la plus grande perle de la nature. L'eau qui coule le long de formes sophistiquées jusqu'à vous et libère – le corps et l'esprit.



Skill, innovation and imagination of designers combining functionality and aesthetics to follow one goal - best use of space. Since **Kerrock** is a non-porous and heatresistant material, it is reasonable to use it for areas exposed to water and heat.

Können, Innovation und Vorstellungskraft der Designer, durch welche Funktionalität mit Ästhetik kombiniert wird, um ein Ziel zu erreichen - die optimale Nutzung des Raumes. Da **Kerrock** ein völlig porenfreies und hitzebeständiges Material ist, kann man es ohne Bedenken in Bereichen verwenden, die Wasser und Hitze ausgesetzt sind.

Savoir-faire, innovation et imagination des concepteurs allient la fonctionnalité et l'esthétique dans un seul but : La gestion de l'espace. Comme il est non poreux et résistant à la chaleur, il convient de l'utiliser dans des zones qui sont en contact avec de l'eau et exposées à une source de chaleur.



*When even such
a small space becomes
a large one.*

*Wenn selbst ein so kleiner Raum
zu einem großen wird.*

*Lorsqu'un si petit
espace devient tellement
grand.*



LIKE TO TRAVEL?
**KERROCK IN
YACHT INTERIES,
MOBILE HOMES,
MOTOR HOMES.**

REISEN SIE
GERNE?
**KERROCK IN
YACHTEN,
WOHNWAGEN,
WOHNMOBILEN.**

AIMEZ-VOUS
VOYAGER ?
**KERROCK DANS
LES INTÉRIEURS
DES YACHTS.
MAISONS
MOBILES,
CARAVANETTES.**

EXTERIOR. KERROCK.

View of a building's facade equipped with Kerrock.
Impression. That lasts and lasts.

Exterior. Kerrock.



Production of
UV-resistant
Kerrock for exterior use.

Produktion von UV-beständigem
Kerrock für Außeneinsatz.

Fabrication du Kerrock résistant
aux rayons UV conçu pour les
applications extérieures.



AUSSEN. KERROCK.

Der erste Eindruck des Gebäudes zählt. Außen.
Kerrock.



EXTERIEUR. KERROCK.

Vue donnant sur la façade d'un bâtiment habillé
de Kerrock. Impression. Qui résiste et persiste.
Extérieur. Kerrock.

Just one glance is enough to feel its greatness.

DURABILITY. QUALITY.

Kerrock ventilated facades prevent losing warmth in winter and preserve optimal climatic conditions in interior spaces in summer.

Nur ein Blick genügt, um seine Größe zu fühlen.

HALTBARKEIT. QUALITÄT.

Durch die Kerrock belüfteten Fassaden werden die Wärmeverluste im Winter verhindert und die optimalen klimatischen Bedingungen in Innenräumen im Sommer bewahrt.

Un regard suffit pour ressentir sa grandeur.

DURABILITÉ. QUALITÉ.

Les façades ventilées Kerrock préviennent la perte de chaleur en hiver et maintiennent des conditions climatiques intérieures optimales en été.



*Stand out!
Kerrock.*

Fallen Sie auf! Kerrock.

Imposez-vous ! Kerrock.



FACES OF
ETERNITY.
FACADES.

FÜR EWIGKEIT
GESCHAFFEN.
FASSADEN.

FAÇADES :
VISAGE DE
L'ÉTERNITÉ.

SHAPES
THAT CREATE
HARMONY IN
SPACE.

FORMEN, DIE
HARMONIE
IM RAUM
SCHAFFEN.

LES FORMES
QUI DÉGAGENT
DE **L'HARMONIE**
DANS L'ESPACE.



Deviations in the shade of bowls and sheets of the same colour may occur. / Zwischen den Waschtischen und den Platten der gleichen Farbe kann zu den Abweichungen in der Nuance kommen. / Il peut y avoir des nuances différentes entre un panneau et une vasque de la même couleur.



WASHBASINS AND SINKS

WASCH- UND
SPÜLBECKEN.

VASQUES ET CUVES.

Among all pieces of furniture, those in kitchen and bathroom are most often in use, so this is why we pay very special attention to them here at Kolpa. Functionality, robustness, ease to clean, sublime style and multiple design options are more than a good reason to choose a washbasin or a sink made from Kerrock.

Küche- und Badmöbel sind die meistgebrauchten Möbelstücke in Ihrem Haus, deswegen schenkt Kolpa diesem Bereich eine ganz besondere Aufmerksamkeit. Funktionalität, Robustheit, einfache Reinigung, hervorragendes Design und vielfache Gestaltungsmöglichkeiten sind mehr als gute Gründe, um ein Wasch- oder Spülbecken aus Kerrock zu wählen.

Les meubles de cuisine et de salle de bains font partie de notre quotidien. C'est pourquoi Kolpa leur accorde une attention particulière. Fonctionnalité, résistance, nettoyage facile, ligne élégante et design sont autant de bonnes raisons de choisir un lavabo ou un évier Kerrock.

Actual dimensions may vary from stated ones (the plan).

Die angegebenen Dimensionen können (vom Entwurf) abweichen.

Les dimensions réelles peuvent différer (de celles du plan).

WASHBASINS / WASCHBECKEN / VASQUES

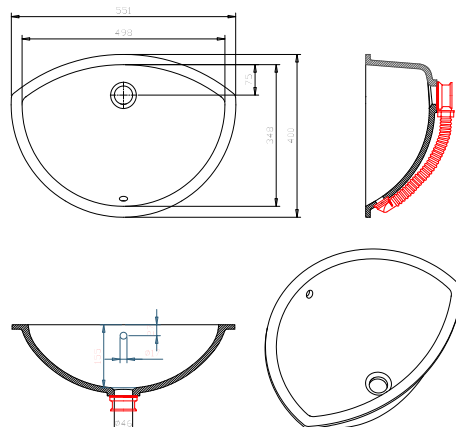

010 SILVIA

498 mm / 348 mm / 155 mm / Ø 46 mm

● 1090, 5080, 5083, 9095

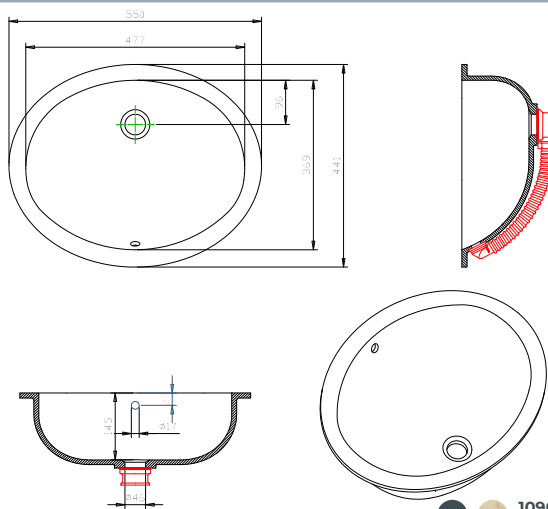

011 TINA

477 mm / 369 mm / 145 mm / Ø 46 mm

● 1090, 5080, 5083, 9095

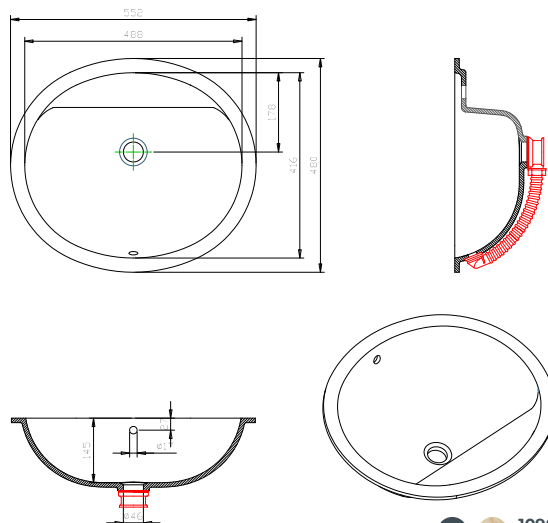

012 PETRA

488 mm / 416 mm / 145 mm / Ø 46 mm

● 1090, 5080, 5083, 9095

● Legend: This washbasin is available in unicolours. / Legende: Dieses Waschbecken ist in Uni Colour Farben erhältlich. / Légende: Modèle disponible dans les coloris unis.

● Legend: This washbasin is available in all granite colours. / Legende: Dieses Waschbecken ist in Granitfarben erhältlich. / Légende: Modèle disponible dans toutes les nuances de granit.

WASHBASINS / WASCHBECKEN / VASQUES

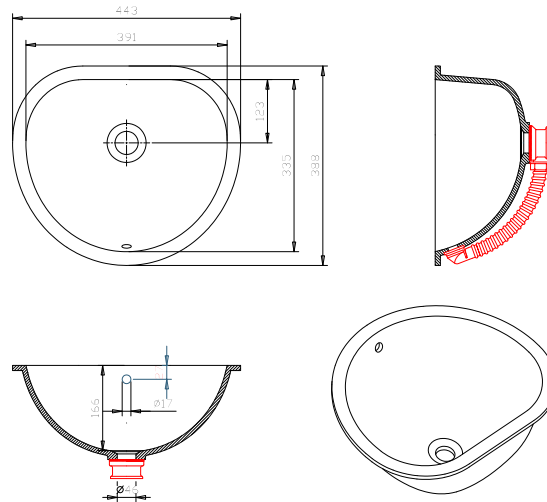

013 TRU
391 mm / 335 mm / 166 mm / Ø 46 mm

● ● 1090, 5080,
5083, 9095

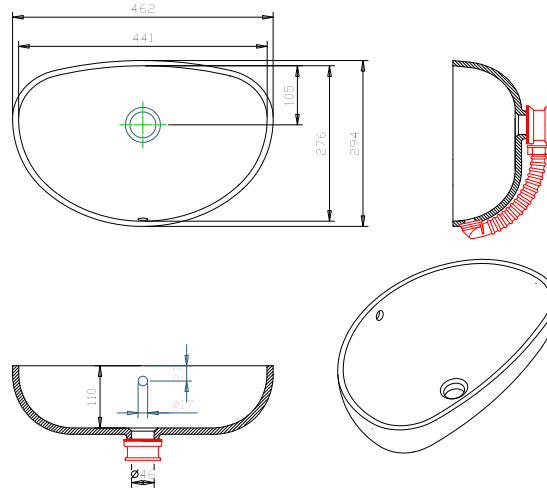

040 SARA
441 mm / 276 mm / 110 mm / Ø 46 mm

● ●

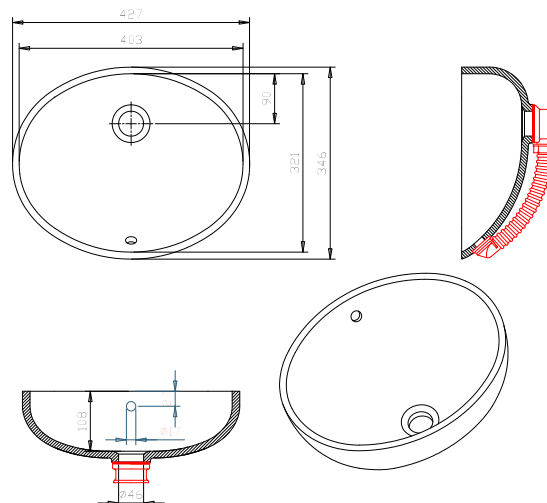

041 BLANCA
403 mm / 321 mm / 108 mm / Ø 46 mm

● ●

● 1090, 5080, 5083, 9095 Legend: This washbasin is available in granite colours 1090, 5080, 5083 in 9095. / Légende: Dieses Waschbecken ist nur in Granitfarben 1090, 5080, 5083 und 9095. / Légende : Modèle disponible uniquement dans les nuances de granit suivantes 1090, 5080, 5083 et 9095.

WASHBASINS / WASCHBECKEN / VASQUES

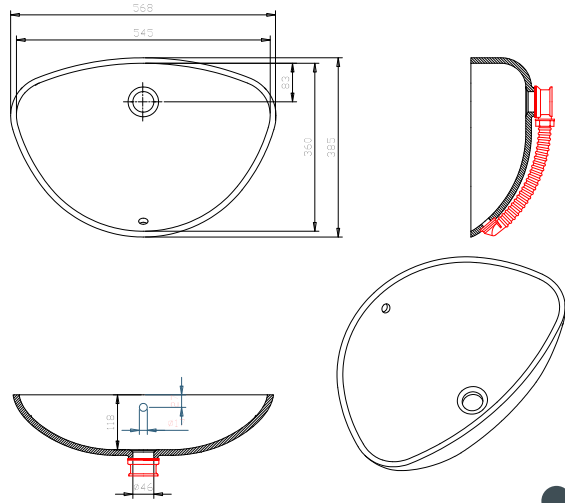

042 LANA

545 mm / 360 mm / 118 mm / Ø 46 mm

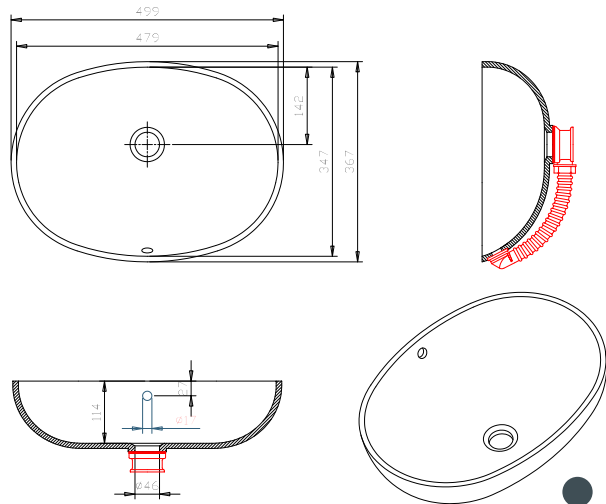

030 EVA

479 mm / 347 mm / 114 mm / Ø 46 mm

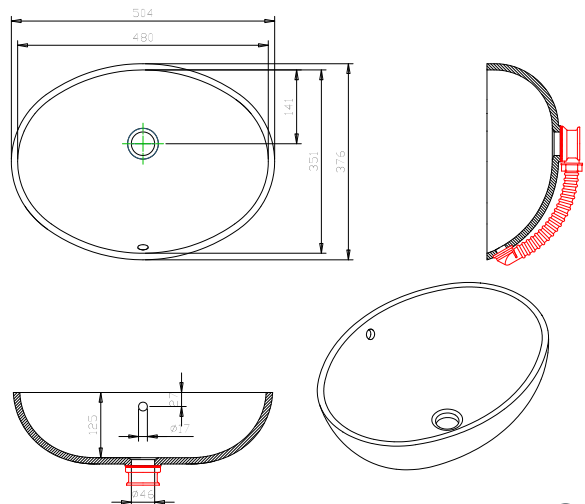

031 MAJA

480 mm / 351 mm / 125 mm / Ø 46 mm



● Legend: This washbasin is available in unicolours. / Legende: Dieses Waschbecken ist in Uni Colour Farben erhältlich. / Légende: Modèle disponible dans les coloris unis.

● Legend: This washbasin is available in all granite colours. / Legende: Dieses Waschbecken ist in Granitfarben erhältlich. / Légende: Modèle disponible dans toutes les nuances de granit.

WASHBASINS / WASCHBECKEN / VASQUES

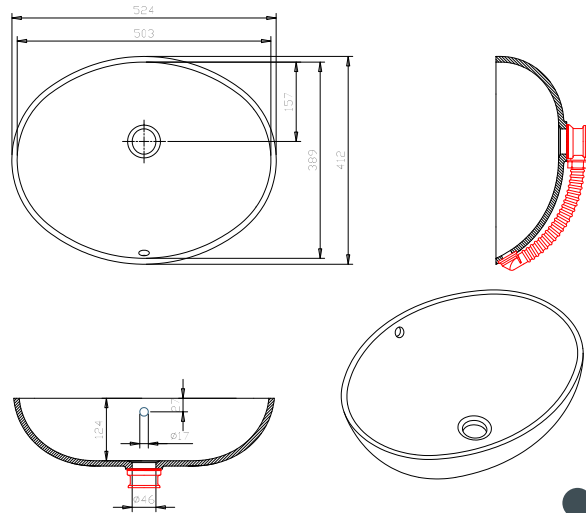

032 IVA
503 mm / 389 mm / 124 mm / Ø 46 mm

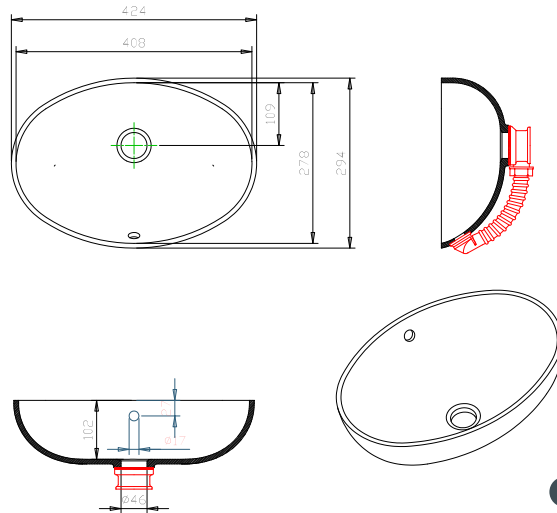

033 ANA
408 mm / 278 mm / 102 mm / Ø 46 mm

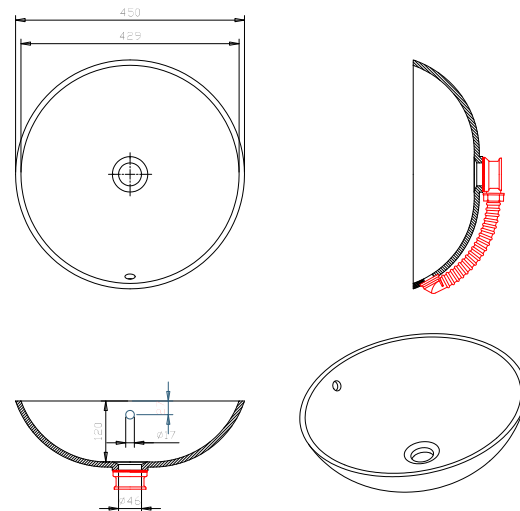

034 RONDO
429 mm / 120 mm / Ø 46 mm

Legend: This washbasin is available in granite colours 1090, 5080, 5083 in 9095. / Légende: Dieses Waschbecken ist nur in Granitfarben 1090, 5080, 5083 und 9095. / Légende: Modèle disponible uniquement dans les nuances de granite suivantes 1090, 5080, 5083 et 9095.

WASHBASINS / WASCHBECKEN / VASQUES



038 META
393 mm / 155 mm / Ø 46 mm

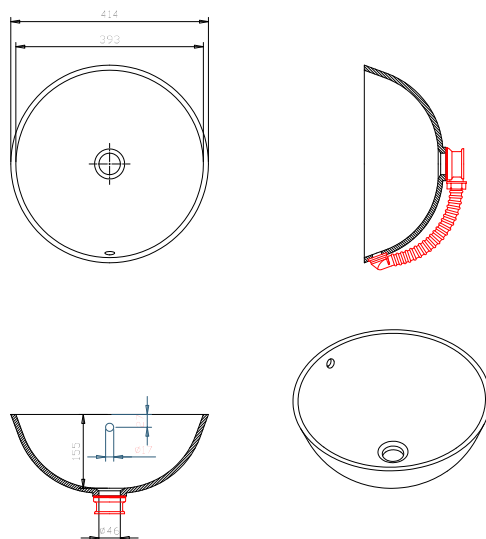

035 KERI
344 mm / 114 mm / Ø 46 mm

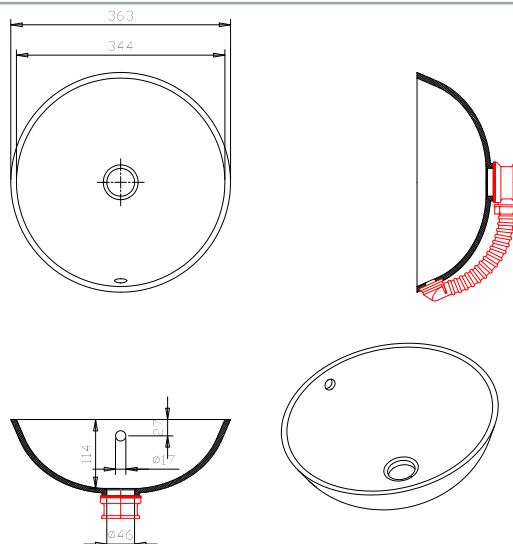

043 JANA
249 mm / 97 mm / Ø 46 mm

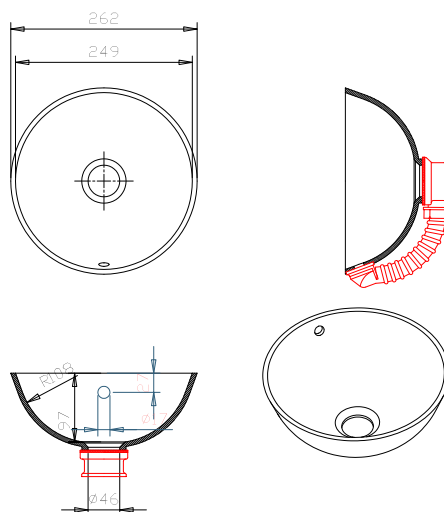

● Legend: This washbasin is available in unicolours. / Legende: Dieses Waschbecken ist in Uni Colour Farben erhältlich. / Légende: Modèle disponible dans les coloris unis.

● Legend: This washbasin is available in all granite colours. / Legende: Dieses Waschbecken ist in Granitfarben erhältlich. / Légende: Modèle disponible dans toutes les nuances de granit.

WASHBASINS / WASCHBECKEN / VASQUES

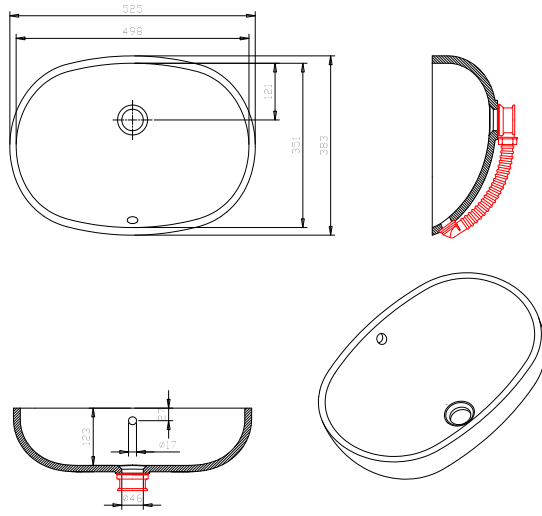

037 AJDA

498 mm / 351 mm / 123 mm / Ø 46 mm

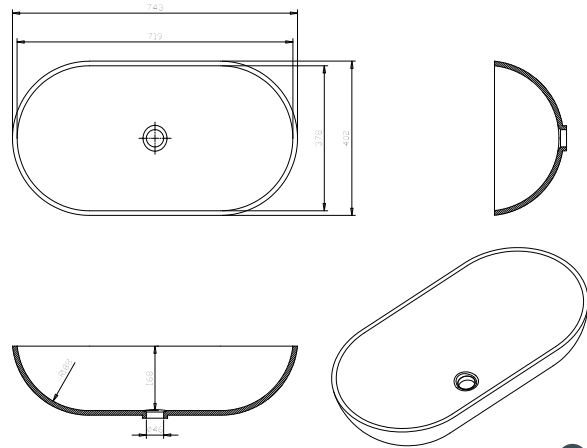

039 BEA

719 mm / 378 mm / 168 mm / Ø 46 mm



NEW

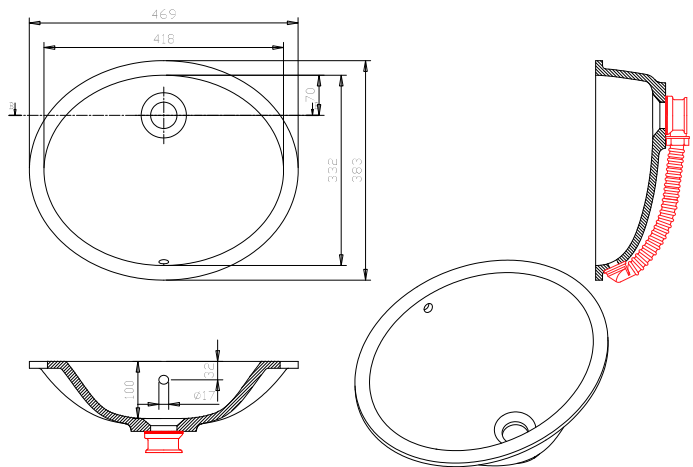

150 TISA

418 mm / 332 mm / 100 mm / Ø 46 mm



1090, 5080, 5083, 9095 Legend: This washbasin is available in granite colours 1090, 5080, 5083 in 9095. / Légende: Dieses Waschbecken ist nur in Granitfarben 1090, 5080, 5083 und 9095.

108 Legend: This washbasin is available in unicolour 108. / Légende: Dieses Waschbecken ist nur in Uni Colour Farbe 108 erhältlich.

WASHBASINS / WASCHBECKEN / VASQUES

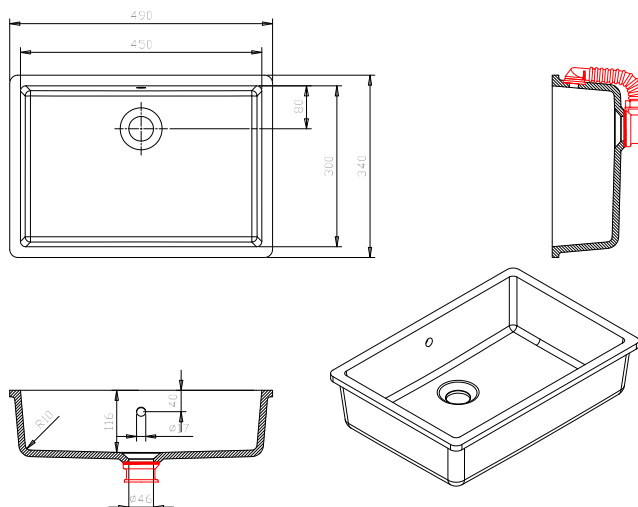

044 BRINA

450 mm / 300 mm / 116 mm / Ø 46 mm

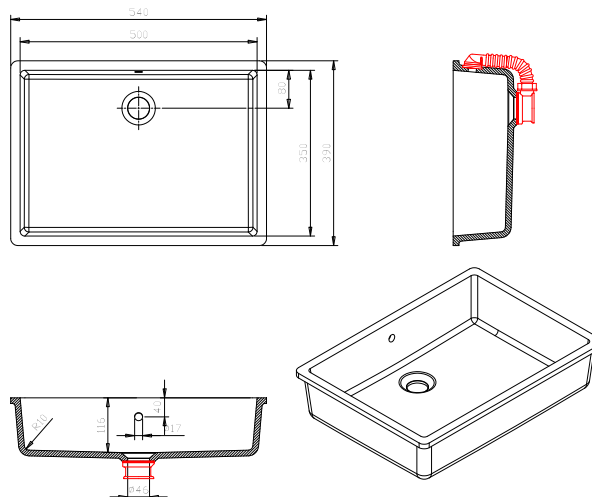

045 CHERI

500 mm / 350 mm / 116 mm / Ø 46 mm

● Legend: This washbasin is available in unicolours. / Legende: Dieses Waschbecken ist in Uni Colour Farben erhältlich. / Légende: Modèle disponible dans les coloris unis.

● Legend: This washbasin is available in all granite colours. / Legende: Dieses Waschbecken ist in Granitfarben erhältlich. / Légende: Modèle disponible dans toutes les nuances de granit.

Usability, robustness, easy cleaning, great style and **multiple design options** are all good reason to choose a washbasin or a sink made from Kerrock.

Benutzerfreundlichkeit, Robustheit, einfache Reinigung, hervorragendes **Design und vielfältige Gestaltungsmöglichkeiten** sind gute Gründe, ein Wasch- oder Spülbecken aus Kerrock zu wählen.

Fonctionnalité, résistance, nettoyage facile, belle apparence et **design sont de bonnes raisons** pour choisir une vasque ou un évier Kerrock.



WASHBASINS / WASCHBECKEN / VASQUES

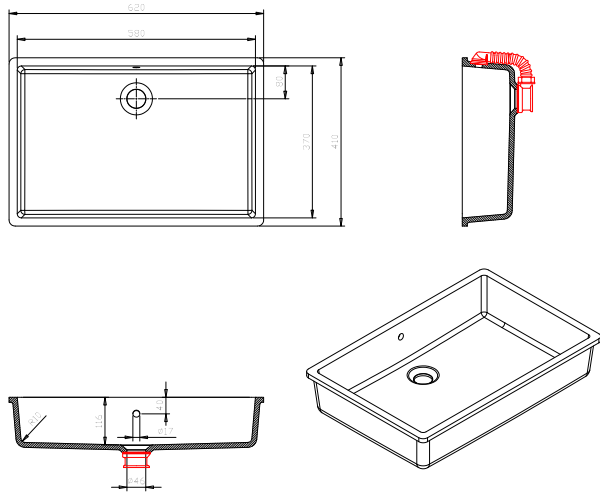

046 LORA

580 mm / 370 mm / 116 mm / Ø 46 mm

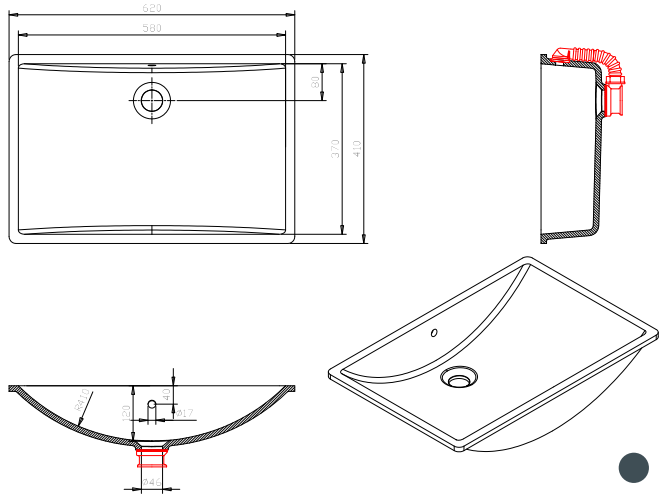

047 KELI

580 mm / 370 mm / 120 mm / Ø 46 mm

● **1090, 5080, 5083, 9095** Legend: This washbasin is available in granite colours 1090, 5080, 5083 in 9095. / Légende: Dieses Waschbecken ist nur in Granitfarben 1090, 5080, 5083 und 9095. / Légende : Modèle disponible uniquement dans les nuances de granit suivantes 1090, 5080, 5083 et 9095.

Kerrock, born to exceed the average!

Kerrock. Hergestellt, um den Durchschnitt zu übertreffen!

Kerrock, créé pour se surpasser !



NON-POROUS
PORENFREI
NON POREUX



WASHBASINS / WASCHBECKEN / VASQUES

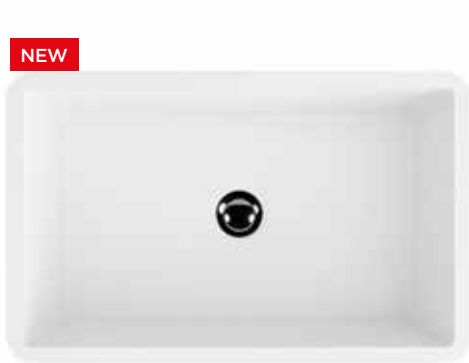

NEW

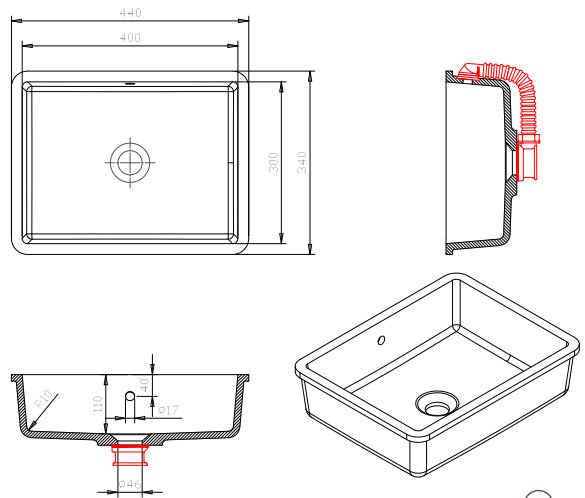

152 INA 400

400 mm / 300 mm / 110 mm / Ø 46 mm

○ 108



NEW

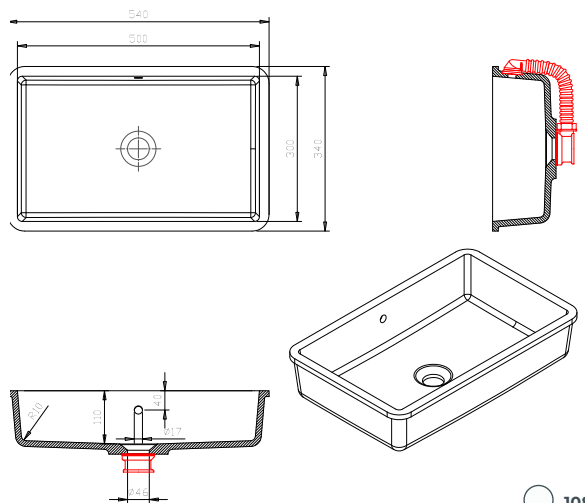

153 INA 500

500 mm / 300 mm / 110 mm / Ø 46 mm

○ 108



NEW

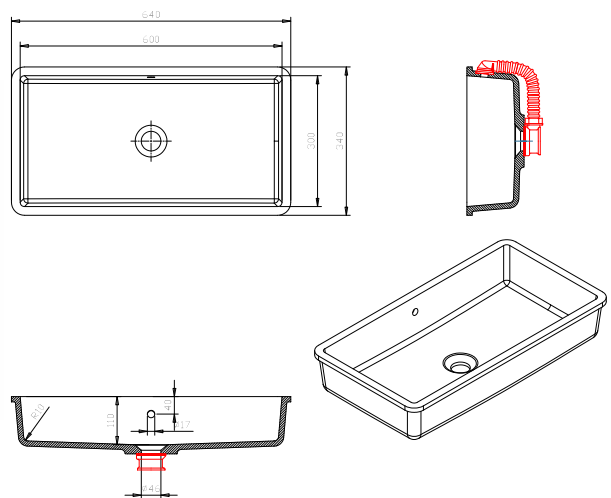

154 INA 600

600 mm / 300 mm / 110 mm / Ø 46 mm

○ 108

○ 108 Legend: This washbasin is available in unicolour 108. / Legende: Dieses Waschbecken ist nur in Uni Colour Farbe 108 erhältlich. / Légende : Modèle disponible uniquement en coloris unis 108.

WASHBASINS / WASCHBECKEN / VASQUES

NEW

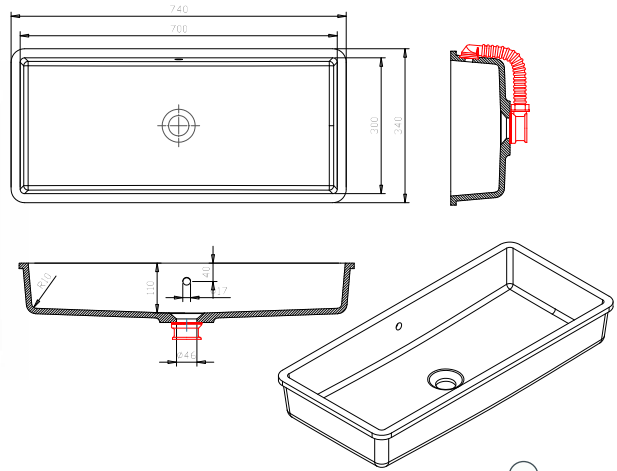

155 INA 700

700 mm / 300 mm / 110 mm / Ø 46 mm

○ 108



○ 108 Legend: This washbasin is available in unicolour 108. / Legende: Dieses Waschbecken ist nur in Uni Colour Farbe 108 erhältlich. / Légende : Modèle disponible uniquement en coloris unis 108.

WASHBASINS / WASCHBECKEN / VASQUES

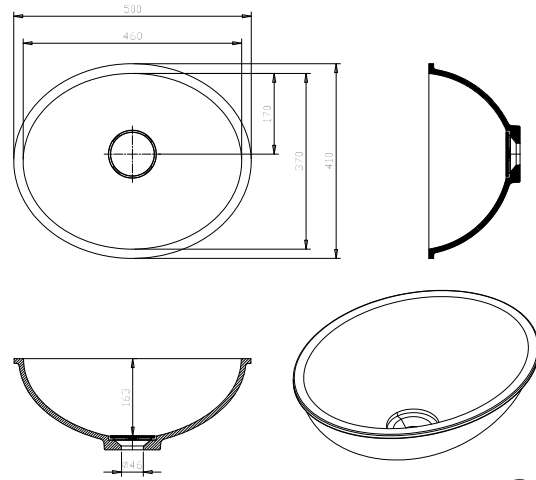

110 VITA

460 mm / 370 mm / 163 mm / Ø 101 mm

○ 108

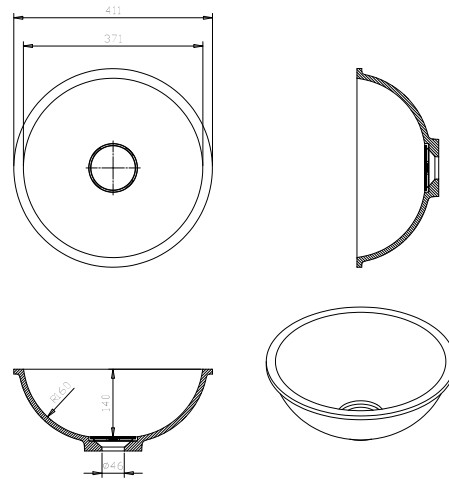
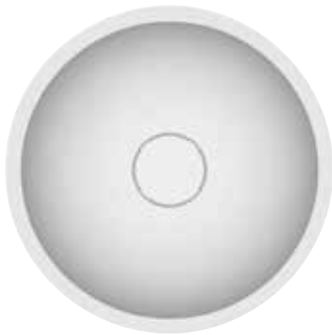

111 IRIS

371 mm / 140 mm / Ø 101 mm

○ 108

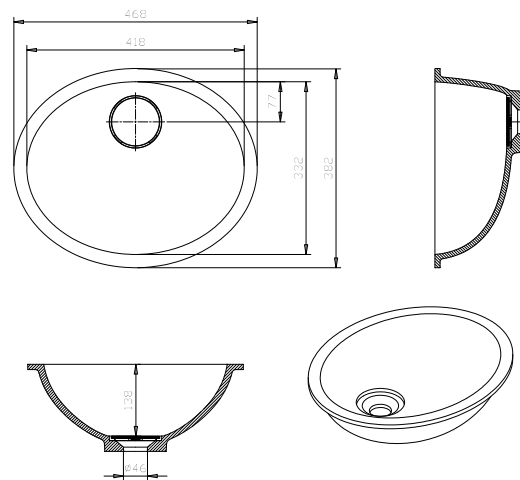

112 ROSA

418 mm / 332 mm / 138 mm / Ø 101 mm

○ 108

○ 108 Legend: This washbasin is available in unicolour 108. / Legende: Dieses Waschbecken ist nur in Uni Colour Farbe 108 erhältlich. / Légende : Modèle disponible uniquement en coloris unis 108.

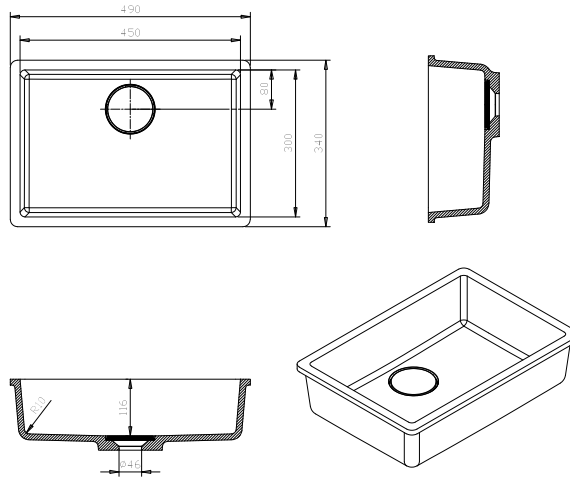

116 BRINA VARIANT
450 mm / 300 mm / 116 mm / Ø 101 mm

○ 108

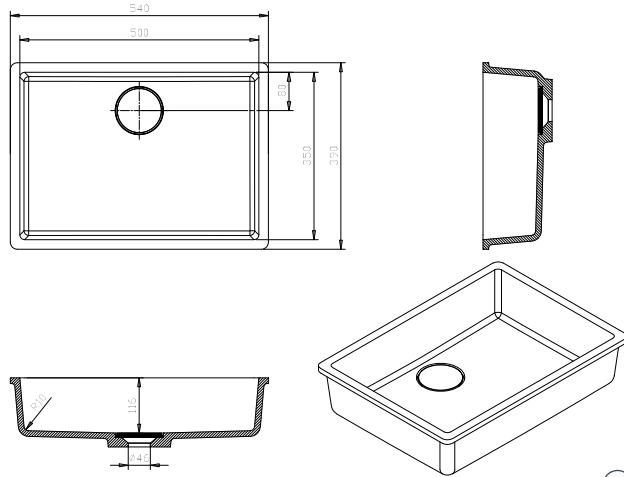

117 CHERI VARIANT
500 mm / 350 mm / 116 mm / Ø 101 mm

○ 108

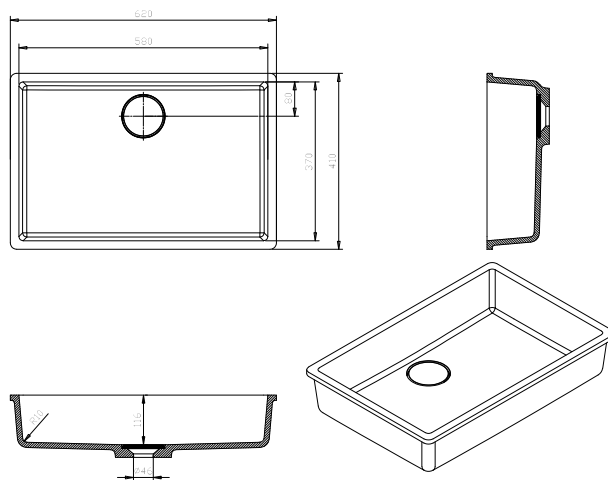
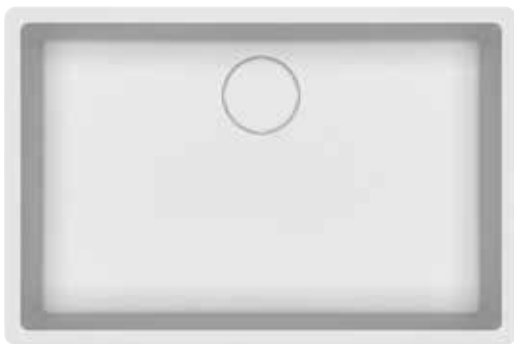

118 LORA VARIANT
580 mm / 370 mm / 116 mm / Ø 101 mm

○ 108

○ 108 Legend: This washbasin is available in unicolour 108. / Legende: Dieses Waschbecken ist nur in Uni Colour Farbe 108 erhältlich. / Légende : Modèle disponible uniquement en coloris unis 108.

WASHBASINS / WASCHBECKEN / VASQUES

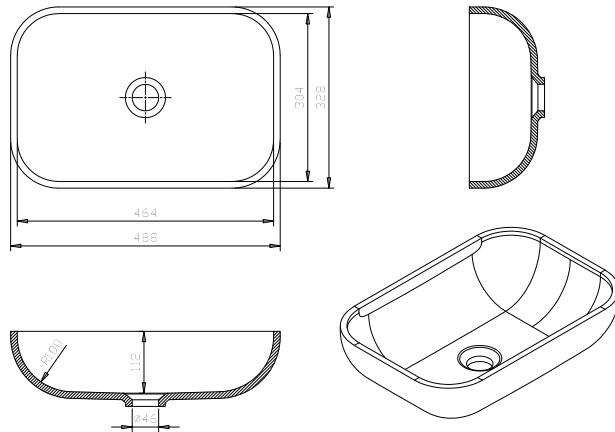

129 ZENA 460

464 mm / 304 mm / 112 mm / Ø 46 mm

○ KERROCK ES 112 (easy shaping)

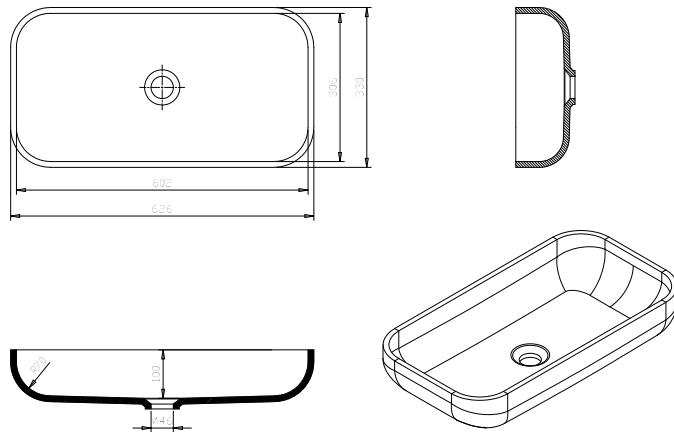

130 ZENA 600

602 mm / 306 mm / 100 mm / Ø 46 mm

○ KERROCK ES 112 (easy shaping)

○ KERROCK ES 112 (easy shaping)

*Infinite
power of imagination.*

*Unendliche Kraft der
Phantasie.*

*L'infini pouvoir de
l'imagination.*



BATHTUB / BADEWANNE / BAIGNOIRE



With legs and outflow and overflow click-clack set.
Füße und Ablaufgarnitur Click-Clack beigelegt.
Fournie avec les pieds et le système de vidage-remplissage click-clack.

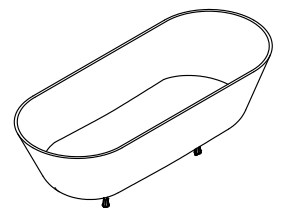
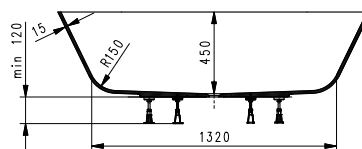
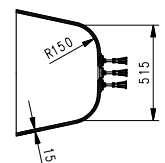
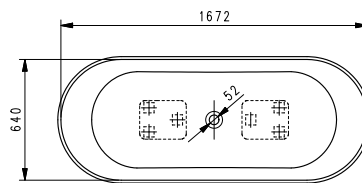

113 ATYS 1670x640 (450)

1672 mm / 640 mm / 450 mm / Ø 52 mm

○ 108

○ 108 Legend: This washbasin is available in unicolour 108. / Legende: Dieses Waschbecken ist nur in Uni Colour Farbe 108 erhältlich. / Légende : Modèle disponible uniquement en coloris unis 108.

BABY BATH / BABYWANNEN / BAINS DE BÉBÉ

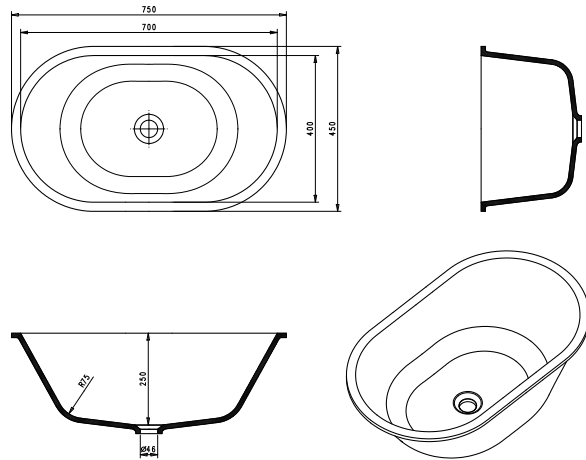

114 SOFIA

700 mm / 400 mm / 250 mm / Ø 46 mm

○ 108

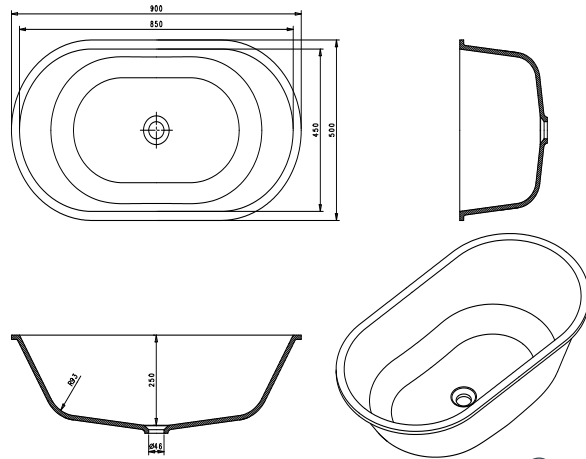

115 ADA

850 mm / 450 mm / 250 mm / Ø 46 mm

○ 108



NEW

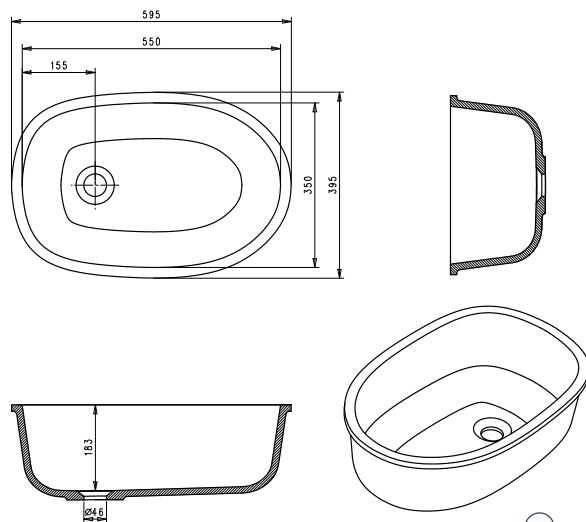

151 HEIDI

550 mm / 350 mm / 183 mm / Ø 46 mm

○ 108

○ 108 Legend: This washbasin is available in unicolour 108. / Legende: Dieses Waschbecken ist nur in Uni Colour Farbe 108 erhältlich. / Légende : Modèle disponible uniquement en coloris unis 108.

BABY BATH / BABYWANNEN / BAINS DE BÉBÉ

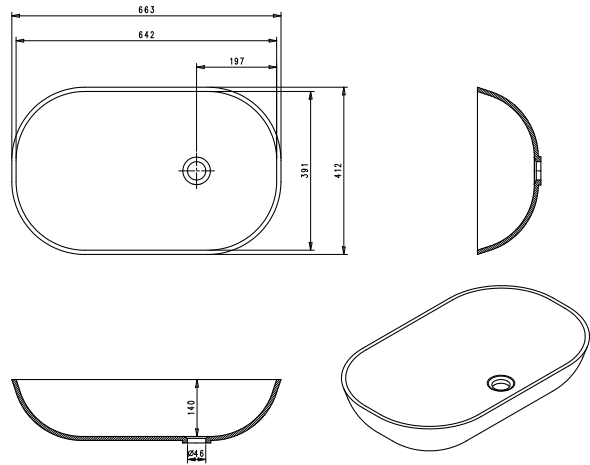

036 BARBI

642 mm / 391 mm / 140 mm / Ø 46 mm



- Legend: This washbasin is available in unicolours. / Legende: Dieses Waschbecken ist in Uni Colour Farben erhältlich. / Légende : Modèle disponible dans les coloris unis.
- Legend: This washbasin is available in all granite colours. / Legende: Dieses Waschbecken ist in Granitfarben erhältlich. / Légende : Modèle disponible dans toutes les nuances de granit.

TRI-VARIO SERIES

An innovative system that uses different variations of washbasins and their installation to provide highly flexible bathroom design. Meet Kerrock Tri-Vario that gives your imagination new dimensions. You can choose between square, round, and oval shape of washbasins and three options of installation: on, in and below the countertop. With any combination you can thus create a functional and aesthetically harmonious bathroom bearing your signature.

Dieses innovative System ermöglicht mit verschiedenen Waschbeckenvariationen und Einbaumöglichkeiten eine außerordentliche Flexibilität bei Badentwurf. Lernen Sie Kerrock tri-vario kennen, das Ihrer Phantasie neue Dimensionen verleiht. Zur Auswahl stehen quadratische, runde oder ovale Form der Waschbecken und drei Einbaumöglichkeiten - über, in und unter den Pult. Mit beliebiger Kombination erstellen Sie sich ein funktionales und ästhetisch harmonisches Bad, dem Sie Ihre persönliche Note verleihen.

Un système innovant qui vous permet, d'obtenir une grande flexibilité dans la conception de votre salle de bains, grâce aux différentes variantes de vasques et à leur installation. Découvrez Kerrock trivario, qui donne à votre imagination une nouvelle dimension. Vous pouvez choisir la forme de votre vasque : carrée, ronde ou ovale. Vous disposez de trois options de montage ; au-dessous, sur et au-dessus du plan de travail. Grâce à la combinaison de votre choix, vous pouvez également créer une salle de bains fonctionnelle et esthétiquement harmonieuse qui porte votre signature.

INSTALLATION EXAMPLES EINBAUMÖGLICHKEITEN EXEMPLES D'INSTALLATIONS

OFELIA



119 OFELIA - ON



120 OFELIA - IN



121 OFELIA - UN

ORIANA



123 ORIANA - ON



124 ORIANA - IN



125 ORIANA - UN

OLIVIA



126 OLIVIA - ON



127 OLIVIA - IN



128 OLIVIA - UN

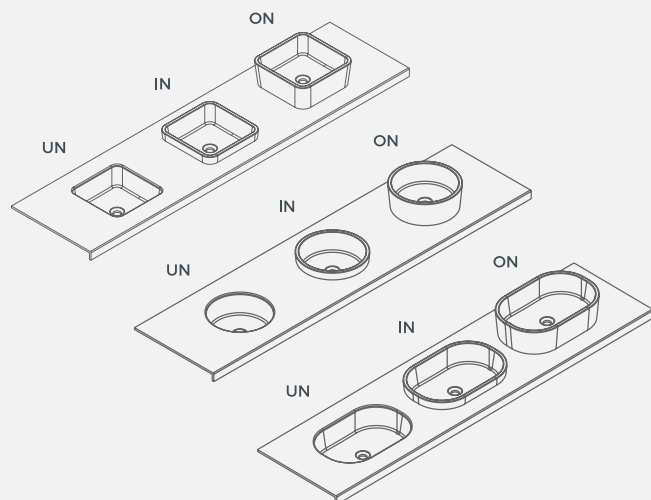

ON - ON COUNTERTOP

IN - IN COUNTERTOP

UN - UNDER COUNTERTOP

TRI-VARIO SERIES / TRI-VARIO SERIES / TRI-VARIO SERIES

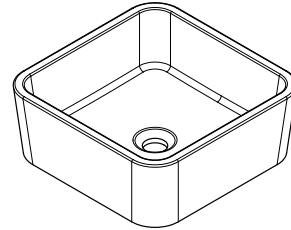
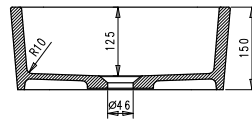
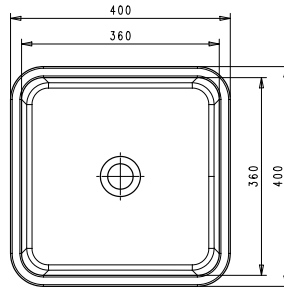

119 OFELIA - ON

360 mm / 360 mm / 125 mm / Ø 46 mm

○ 108

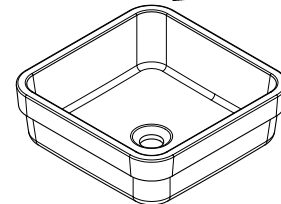
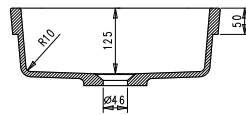
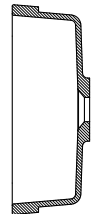
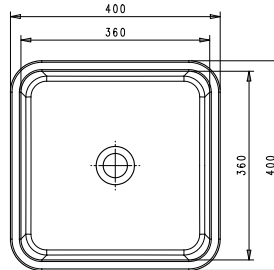

120 OFELIA - IN

360 mm / 360 mm / 125 mm / Ø 46 mm

○ 108

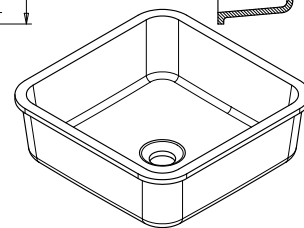
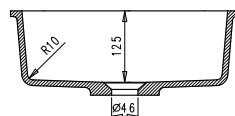
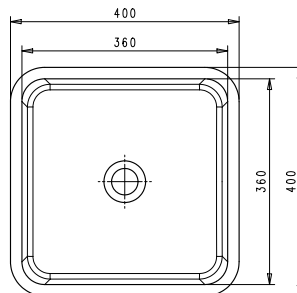

121 OFELIA - UN

360 mm / 360 mm / 125 mm / Ø 46 mm

○ 108

○ 108 Legend: This washbasin is available in unicolour 108. / Legende: Dieses Waschbecken ist nur in Uni Colour Farbe 108 erhältlich. / Légende : Modèle disponible uniquement en coloris unis 108.

TRI-VARIO SERIES / TRI-VARIO SERIES / TRI-VARIO SERIES

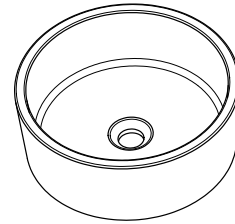
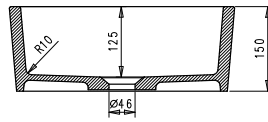
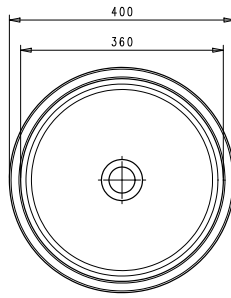

123 ORIANA - ON
360 mm / 125 mm / Ø 46 mm

○ 108

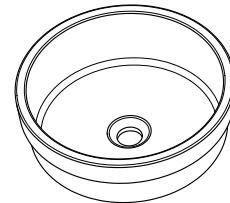
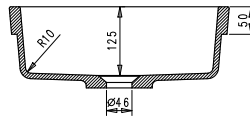
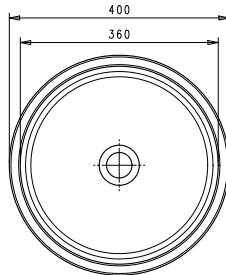

124 ORIANA - IN
360 mm / 125 mm / Ø 46 mm

○ 108

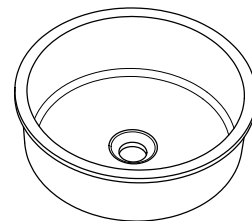
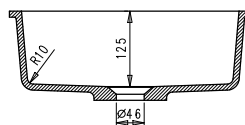
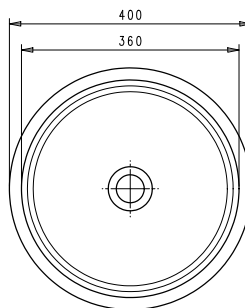

125 ORIANA - UN
360 mm / 125 mm / Ø 46 mm

○ 108

○ 108 Legend: This washbasin is available in unicolour 108. / Legende: Dieses Waschbecken ist nur in Uni Colour Farbe 108 erhältlich. / Légende: Modèle disponible uniquement en coloris unis 108.

TRI-VARIO SERIES / TRI-VARIO SERIES / TRI-VARIO SERIES

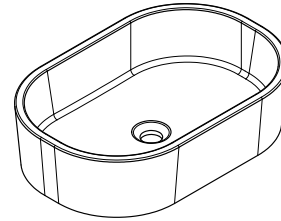
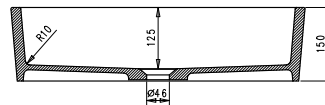
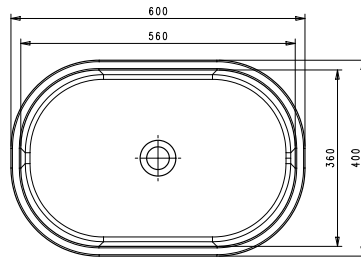

126 OLIVIA - ON
560 mm / 360 mm / 125 mm / Ø 46 mm

○ 108

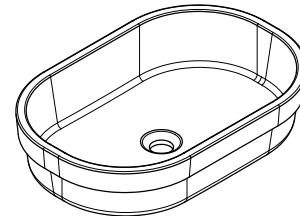
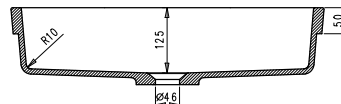
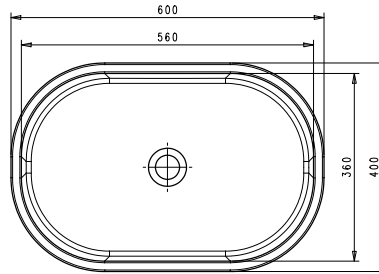

127 OLIVIA - IN
560 mm / 360 mm / 125 mm / Ø 46 mm

○ 108

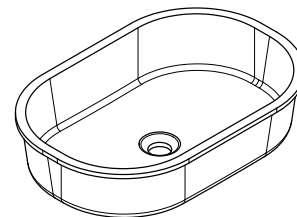
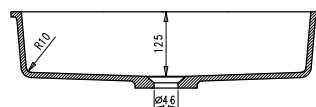
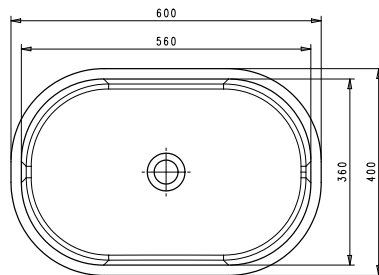

128 OLIVIA - UN
560 mm / 360 mm / 125 mm / Ø 46 mm

○ 108

○ 108 Legend: This washbasin is available in unicolour 108. / Legende: Dieses Waschbecken ist nur in Uni Colour Farbe 108 erhältlich. / Légende : Modèle disponible uniquement en coloris unis 108.

TRI-VARIO SERIES / TRI-VARIO SERIES / TRI-VARIO SERIES

NEW

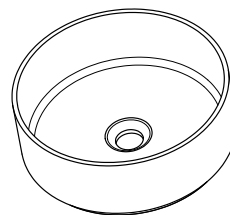
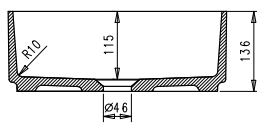
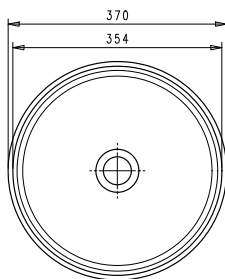

149 RITA - ON
354 mm / 115 mm / Ø 46 mm

○ 108

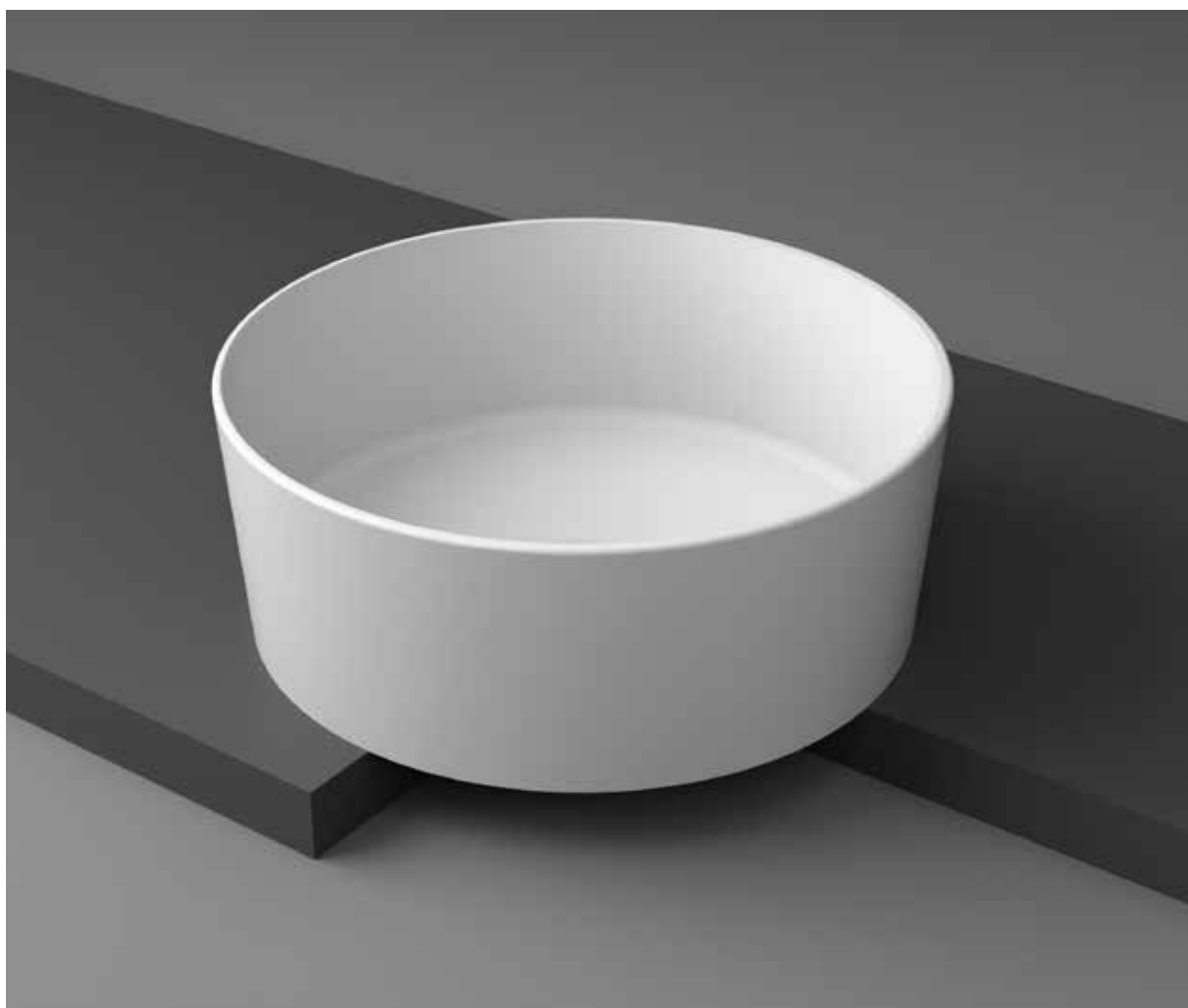

○ 108 Legend: This washbasin is available in unicolour 108. / Legende: Dieses Waschbecken ist nur in Uni Colour Farbe 108 erhältlich. / Légende : Modèle disponible uniquement en coloris unis 108.

WASHBASINS ACCORDING TO YOUR WISHES

The table below shows an example of a few additional dimensions of Lina and Luna washbasins. Based on technical drawings we can create for you a washbasin of custom dimensions.

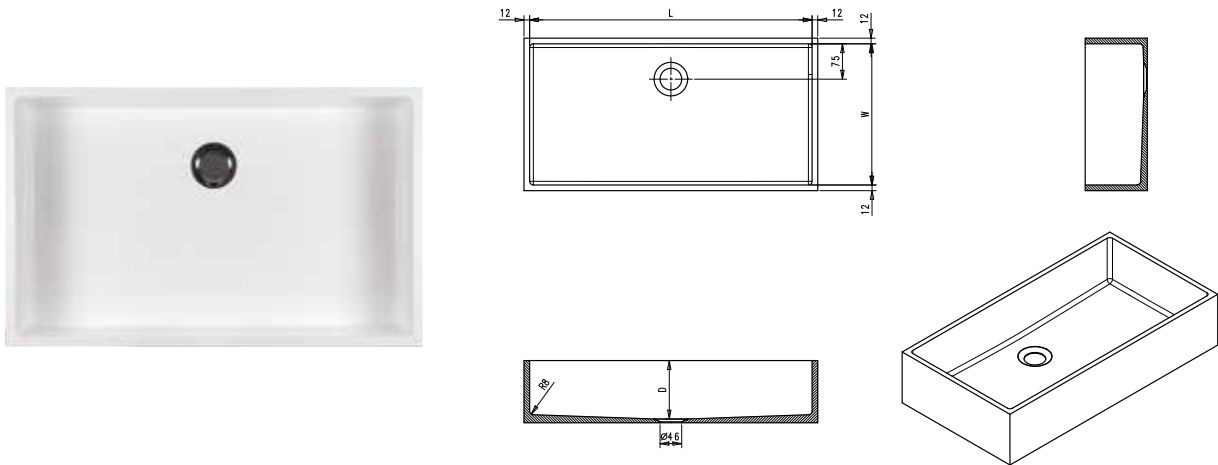

145 LINA



SUGGESTED DIMENSIONS / VORGESCHLAGENE DIMENSIONEN / DIMENSIONS PROPOSÉES

LINA 300 / 300 / 120 / 46	LINA 300 / 350 / 120 / 46	LINA 300 / 370 / 120 / 46
LINA 400 / 300 / 120 / 46	LINA 400 / 350 / 120 / 46	LINA 400 / 370 / 120 / 46
LINA 500 / 300 / 120 / 46	LINA 500 / 350 / 120 / 46	LINA 500 / 370 / 120 / 46
LINA 600 / 300 / 120 / 46	LINA 600 / 350 / 120 / 46	LINA 600 / 370 / 120 / 46

DIMENSIONS BY ORDER / DIMENSION NACH BESTELLUNG / DIMENSIONS SUR DEMANDE

	L (Length / Länge / Longueur)	W (Width / Breite / Largeur)	D (Depth / Tiefe / Profondeur)
LINA	300 - 1200	300 - 600	50 - 500

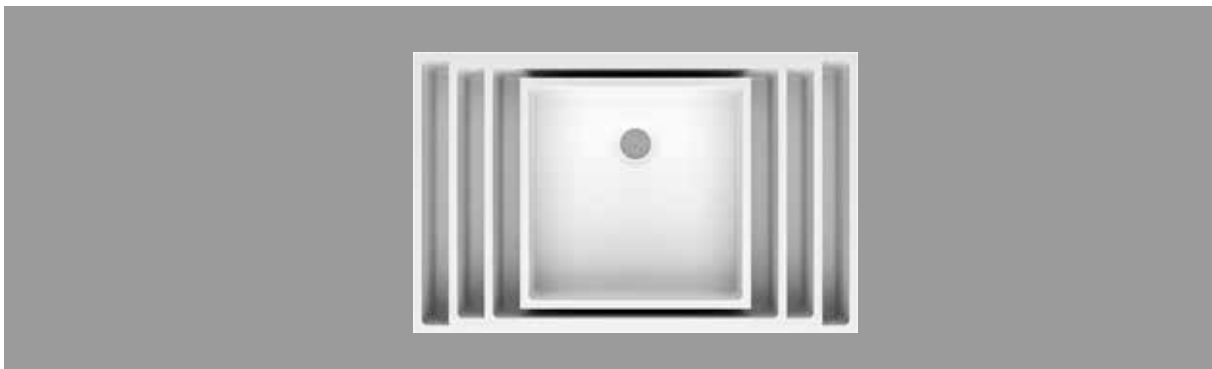

Legend: Washbasins available in unicolours, granite and teraco colours. / Legende: Der Waschbecken ist in Uni Colour Farben, Granit- sowie Teraco-Farben erhältlich. / Légende : Modèle disponible en coloris unis, granit et terraco.

WACHBECKEN KOMPLETT NACH IHREN WÜNSCHEN

In der unteren Tabelle gibt es einige zusätzliche Dimensionen der Waschbecken Lina und Luna. Natürlich ist es auch möglich aufgrund der technischen Skizze ein Waschbecken in einer Dimension nach Maß anzufertigen.

DES VASQUES SELON VOS ENVIES

Le tableau ci-dessous montre un exemple de dimensions possibles des vasques Lina et Luna. Bien sûr, nous pouvons également créer une vasques aux dimensions personnalisées sur la base de dessins techniques.

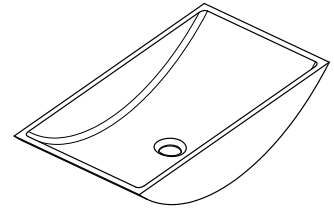
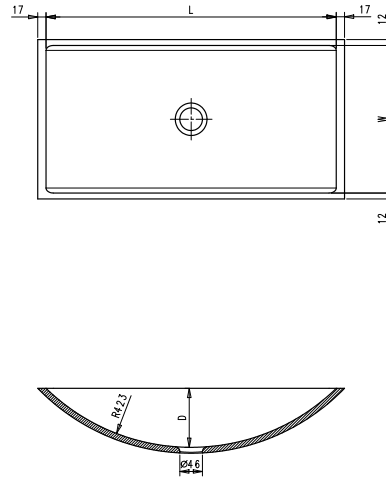

146 LUNA



SUGGESTED DIMENSIONS / VORGESCHLAGENE DIMENSIONEN / DIMENSIONS PROPOSÉES

LUNA 300 / 300 / 120 / 46	LUNA 300 / 350 / 120 / 46	LUNA 300 / 370 / 120 / 46
LUNA 400 / 300 / 120 / 46	LUNA 400 / 350 / 120 / 46	LUNA 400 / 370 / 120 / 46
LUNA 500 / 300 / 120 / 46	LUNA 500 / 350 / 120 / 46	LUNA 500 / 370 / 120 / 46
LUNA 600 / 300 / 120 / 46	LUNA 600 / 350 / 120 / 46	LUNA 600 / 370 / 120 / 46

DIMENSIONS BY ORDER / DIMENSION NACH BESTELLUNG / DIMENSIONS SUR DEMANDE

	L (Length / Länge / Longueur)	W (Width / Breite / Largeur)	D (Depth / Tiefe / Profondeur)
LUNA	300 - 1200	300 - 600	50 - 500

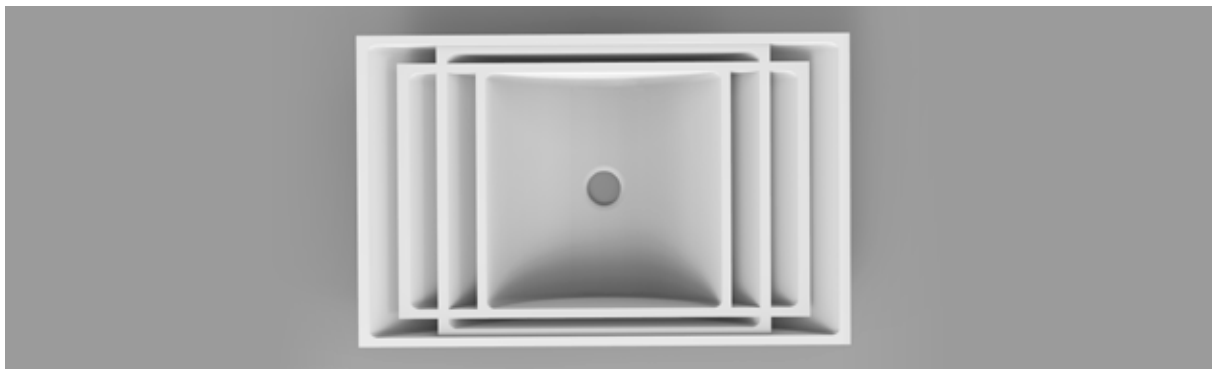

Legend: Washbasins available in unicolours, granite and teraco colours. / Legende: Der Waschbecken ist in Uni Colour Farben, Granit- sowie Teraco-Farben erhältlich. / Légende : Modèle disponible en coloris unis, granit et terraco.

WASHBASIN FOR DISABLED

In our company, we pay special attention to people with disabilities. Washbasins for disabled people must allow enough space for the knees and thighs, while the drain should be positioned as close to the wall as possible. The height of the latter depends on the height of the user in a wheelchair and ranges between 65 and 70 cm.

BEHINDERTEGERECHTER WASCHBECKEN

In unserem Unternehmen widmen wir viel Aufmerksamkeit auch behinderten Menschen. Behindertengerechter Waschbecken soll genügend Platz für Knien und Oberschenkel ermöglichen. Der Ablauf ist so nah wie möglich an die Wand positioniert. Die Höhe des Ablaufs hängt von der Größe des im Rollstuhl sitzenden Benutzers ab und beträgt zwischen 65 und 70 cm.



147
600-2000 mm / 500 mm / Ø 46 mm

VASQUE ADAPTÉE AUX PERSONNES HANDICAPÉES

Dans notre société, nous portons une attention particulière aux personnes handicapées. Les vasques conçues pour les personnes handicapées doivent laisser suffisamment d'espace pour les genoux et les cuisses, et le tuyau doit être positionné le plus près du mur. La hauteur de la vasque est dépendante de la taille de la personne en fauteuil roulant, mais elle varie entre 65 et 70 cm.



108

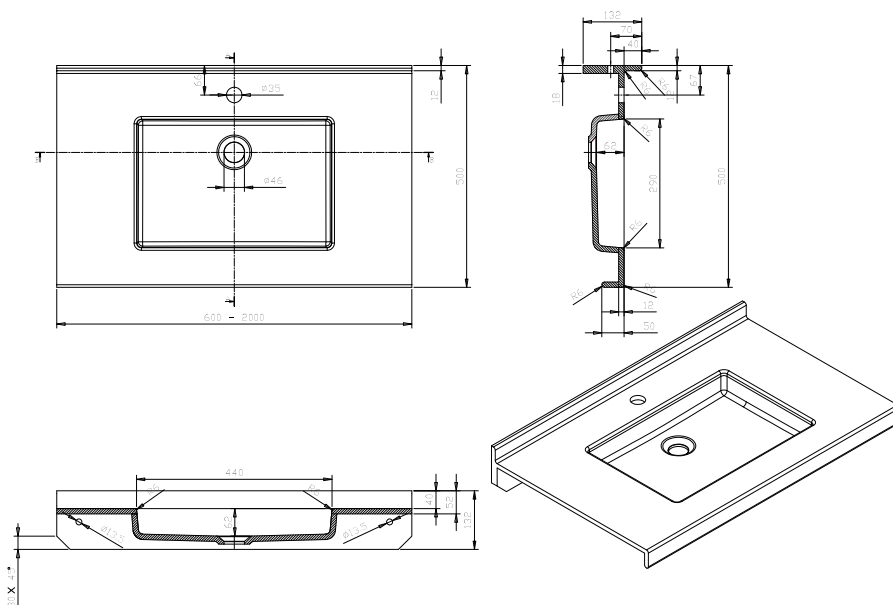

KITCHEN IS
THE HEART OF
YOUR HOME.
WITH KERROCK
IT BECOMES
LOVE.

IHRE KÜCHE
IST DAS HERZ
IHRES HAUSE.
MIT KERROCK
WIRD SIE
**PERFEKT
AUSSEHEN.**

LA CUISINE EST
LE COEUR DE
LA MAISON.
ELLE SE
TRANSFORME
EN **AMOUR**
GRÂCE AU
KERROCK.

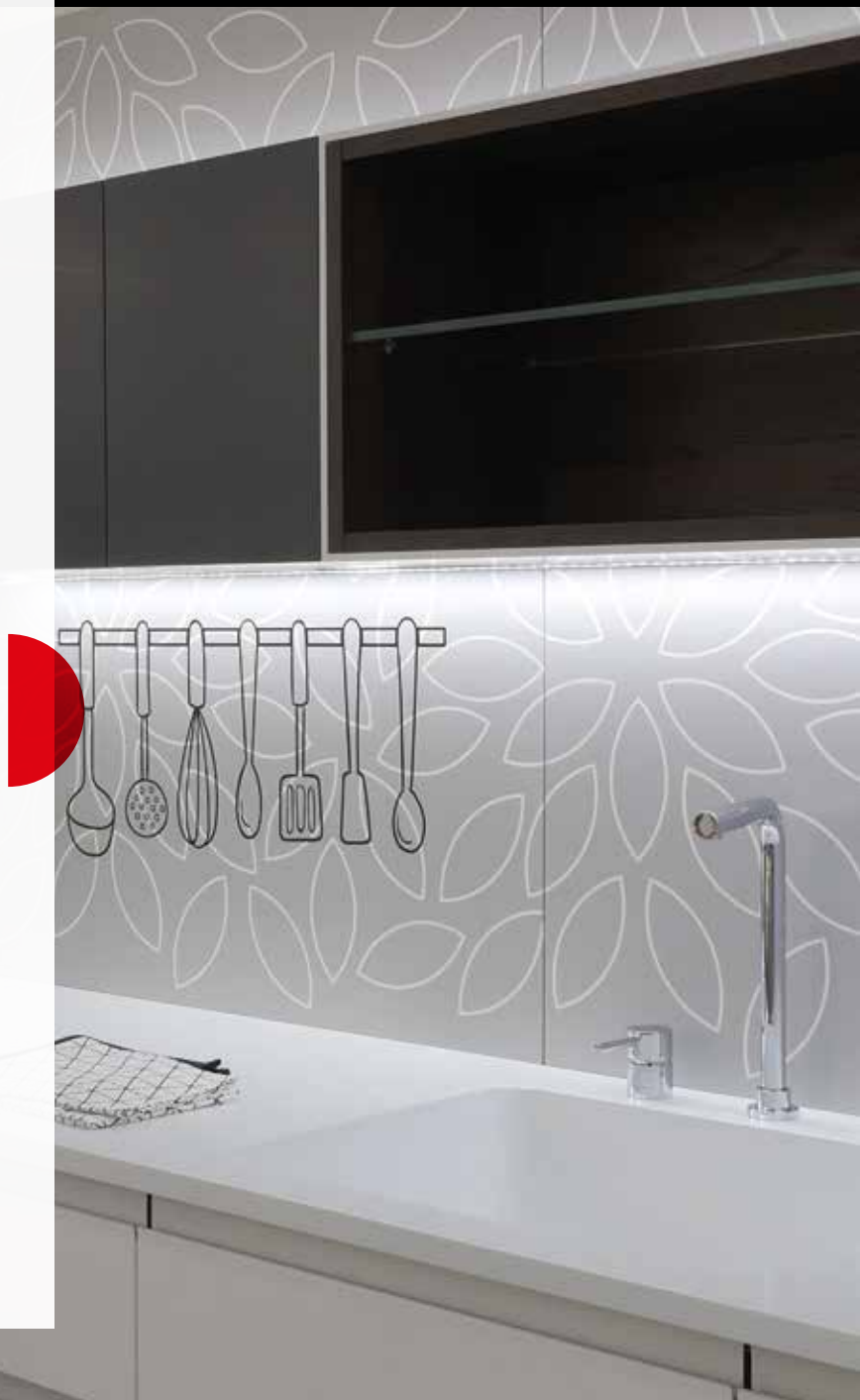

Deviations in the shade of bowls and sheets of the same colour may occur. / Zwischen den Waschtischen und den Platten der gleichen Farbe kann zu den Abweichungen in der Nuance kommen. / Il peut y avoir des nuances différentes entre un panneau et une vasque de la même couleur.



KITCHEN SINKS

SPÜLBECKEN ÉVIERS DE CUISINE

A day, starting with a fragrant cup of coffee and a look at the beautiful shapes of Kerrock, is a good day.

Health-friendly, resistant to mechanical impact, and of great aesthetics. The Kerrock kitchen.

Der Tag, der mit einem herrlich duftenden Tasse Kaffee und mit dem Blick auf die schönen Formen von Kerrock anfängt, wird ein angenehmer Tag sein.

Gesundheitsfreundlich, umweltfreundlich, mechanisch fest und zeitlos. Eine Kerrock Küche.

Commencer la journée avec une tasse de café parfumé et le regard posé sur de magnifiques formes en Kerrock, c'est commencer une bonne journée.

Sain et résistant aux chocs, avec un esthétique immense. La cuisine Kerrock.

Actual dimensions may vary from stated ones (the plan).

Die angegebenen Dimensionen können (vom Entwurf) abweichen.

Les dimensions réelles peuvent différer (de celles du plan).

KITCHEN SINKS / SPÜLBECKEN / ÉVIERS DE CUISINE

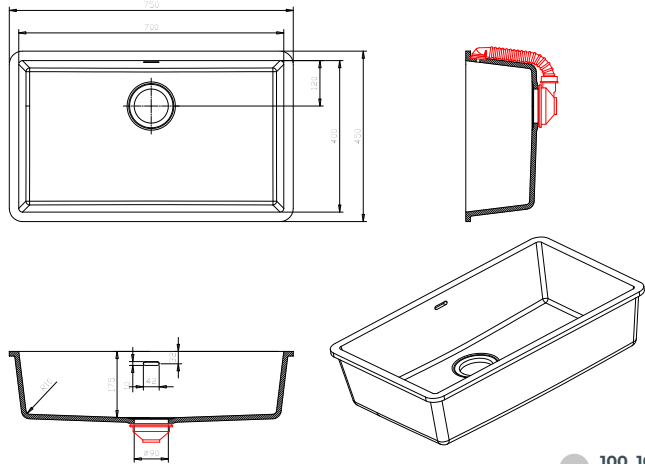

131 BETA

700 mm / 400 mm / 175 mm / Ø 90 mm

● 100, 108, 503, 901

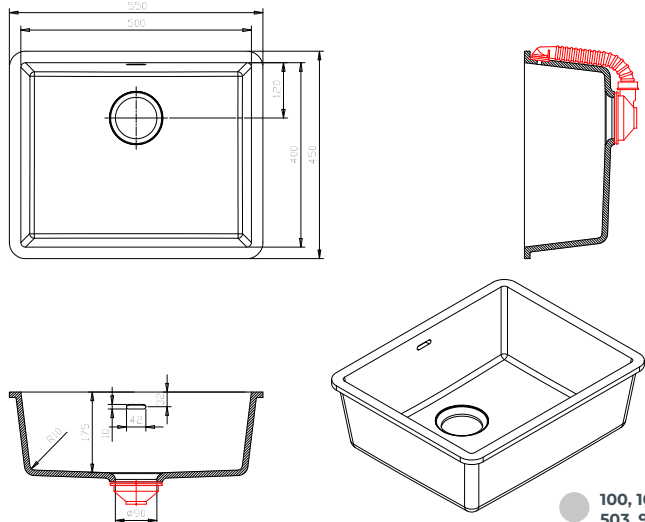

132 CORA

500 mm / 400 mm / 175 mm / Ø 90 mm

● 100, 108, 503, 901

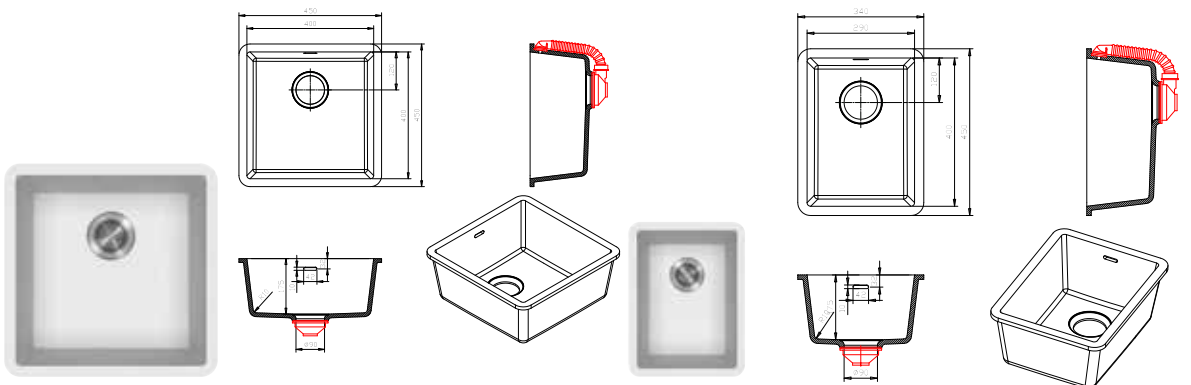

133 FLORA

400 mm / 400 mm / 175 mm / Ø 90 mm

● 100, 108, 503, 901

134 ALYA

290 mm / 400 mm / 175 mm / Ø 90 mm

● 100, 108, 503, 901

● 100, 108, 503, 901 Legend: This washbasin is available in unicolour 100, 108, 503, 901. / Legende: Dieses Waschbecken ist nur in Uni Colour Farbe 100, 108, 503, 901 erhältlich. / Légende: Modèle disponible uniquement en coloris unis 100, 108, 503, 901.

KITCHEN SINKS / SPÜLBECKEN / ÉVIERS DE CUISINE

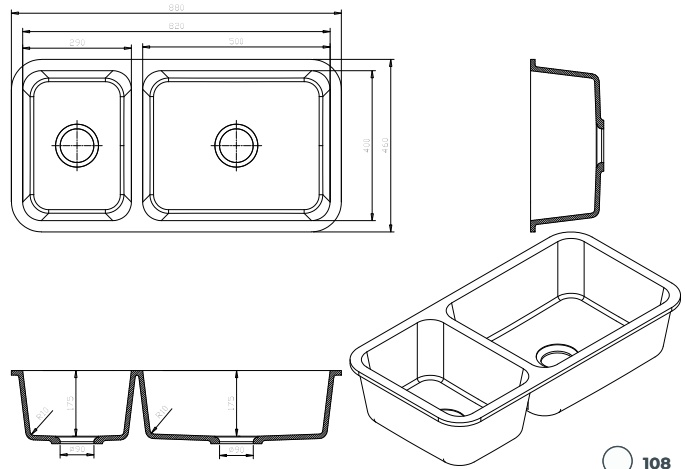

148 HELEN

820 mm / 400 mm / 175 mm / Ø 90 mm

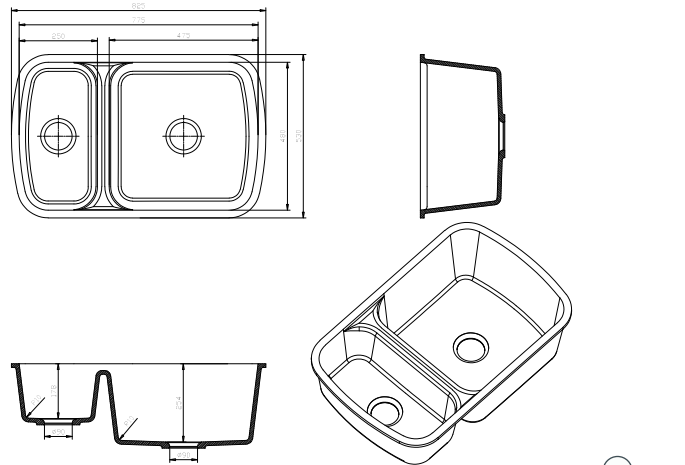

135 CARLA

775 mm / 480 mm / 254 mm / Ø 90 mm

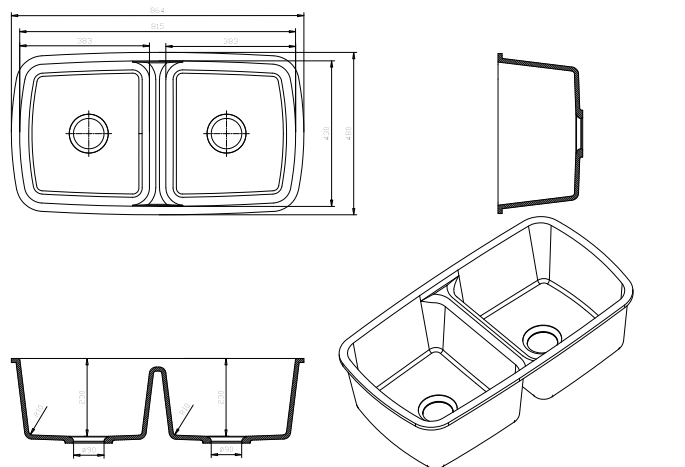

136 BINA

815 mm / 430 mm / 230 mm / Ø 90 mm

○ 108 Legend: This washbasin is available in unicolour 108. / Legende: Dieses Waschbecken ist nur in Uni Colour Farbe 108 erhältlich. / Légende : Modèle disponible uniquement en coloris unis 108.

KITCHEN SINKS / SPÜLBECKEN / ÉVIERS DE CUISINE

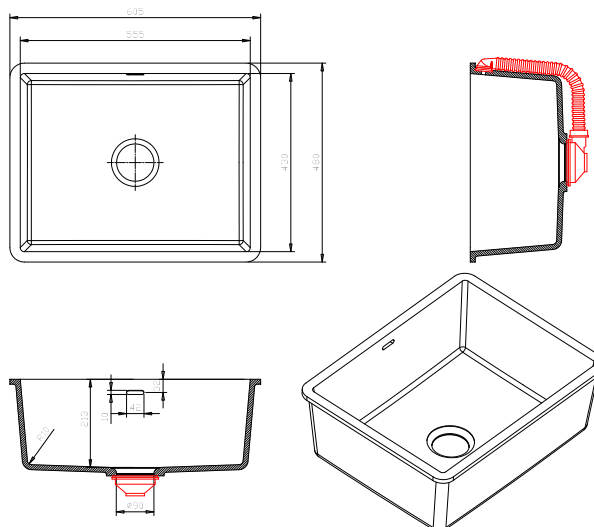

137 KHLOE

555 mm / 430 mm / 213 mm / Ø 90 mm

● 100, 108, 503, 901

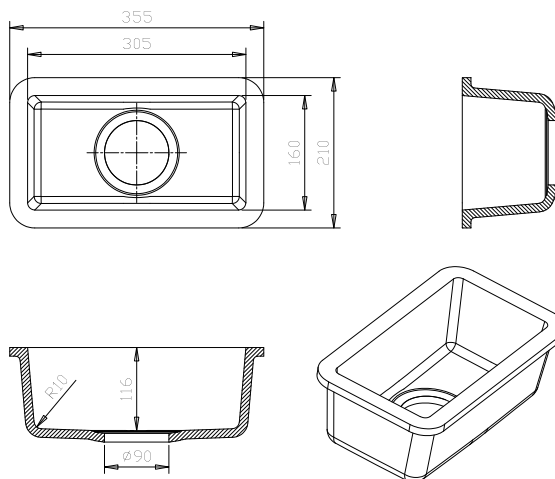

138 PIKA

305 mm / 160 mm / 116 mm / Ø 90 mm

● 100, 108, 503, 901

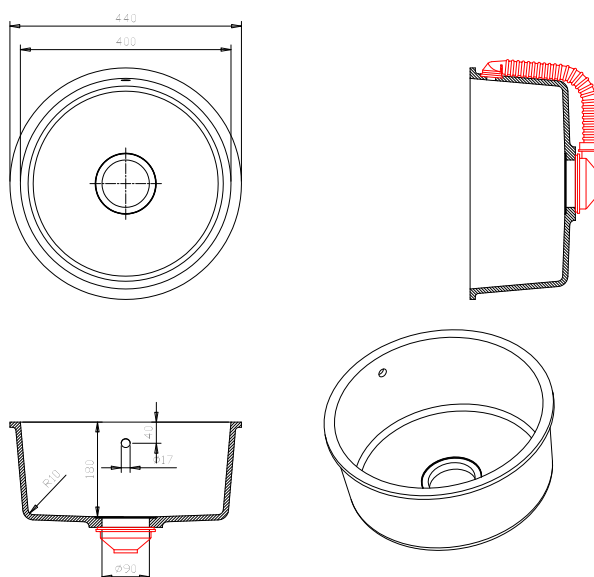

122 ALITA

400 mm / 180 mm / Ø 90 mm

● 100, 108, 503, 901

● 100, 108, 503, 901 Legend: This washbasin is available in unicolour 100, 108, 503, 901. / Legende: Dieses Waschbecken ist nur in Uni Colour Farbe 100, 108, 503, 901 erhältlich. / Légende : Modèle disponible uniquement en coloris unis 100, 108, 503, 901.

KITCHEN SINKS / SPÜLBECKEN / ÉVIERS DE CUISINE

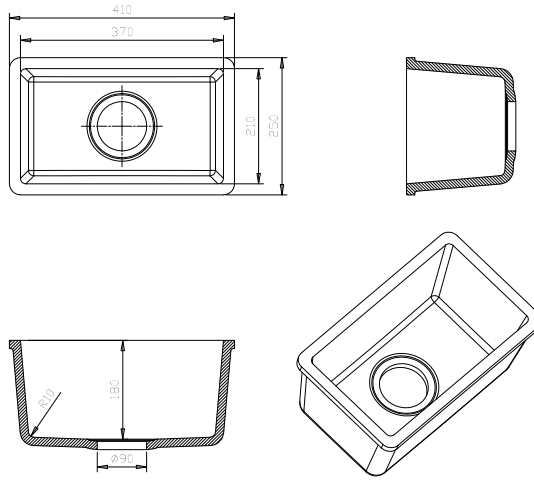

059 SONIA
370 mm / 210 mm / 180 mm / Ø 90 mm

● 1090, 5080,
5083, 9095

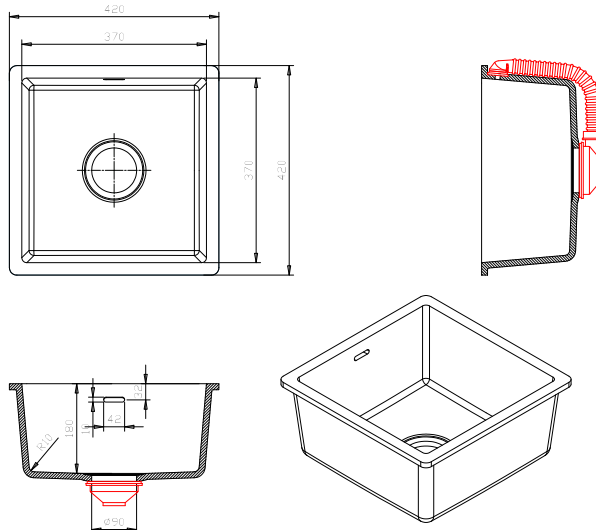

060 EMMA
370 mm / 370 mm / 180 mm / Ø 90 mm

● 1090, 5080,
5083, 9095

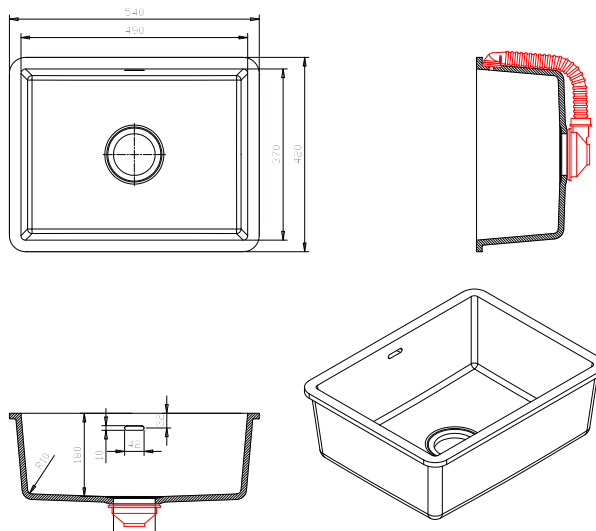

061 NADIA
490 mm / 370 mm / 180 mm / Ø 90 mm

● 1090, 5080,
5083, 9095

● Legend: This washbasin is available in unicolours. / Legende: Dieses Waschbecken ist in Uni Colour Farben erhältlich. / Légende : Modèle disponible dans les coloris unis.

● 1090, 5080, 5083, 9095 Legend: This washbasin is available in granite colours 1090, 5080, 5083 in 9095. / Legende: Dieses Waschbecken ist nur in Granitfarben 1090, 5080, 5083 und 9095. / Légende : Modèle disponible uniquement dans les nuances de granit suivantes 1090, 5080, 5083 et 9095.

KERROCK INNOXATION

Kerrock and Inox. United in a symbiosis of functionality and aesthetics.
In a play of unusual yet so sensible. For those who want to stand out in
an innovative intertwining of two materials.
Interweaving that forms a new image of the future. Your kitchen.

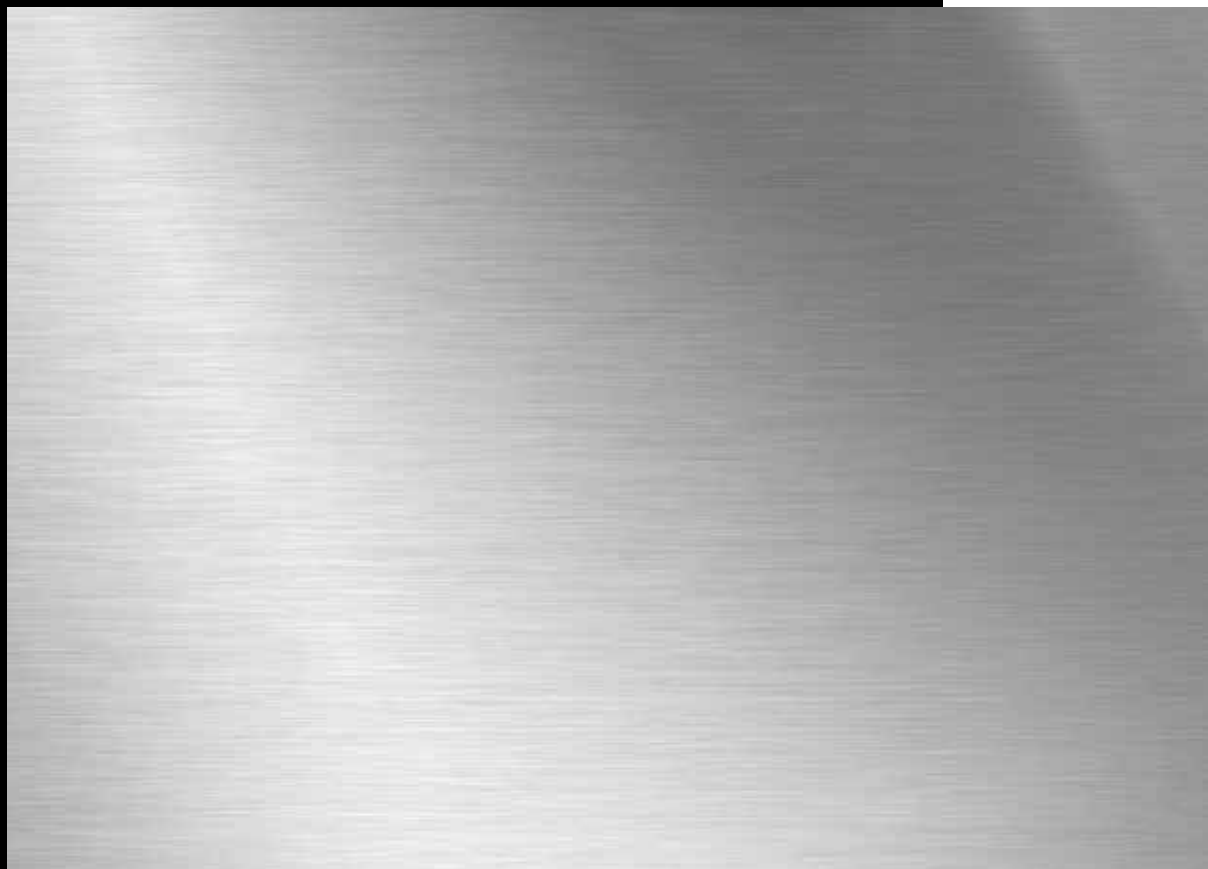

Kerrock und Inox. Vereint in Symbiose der Funktionalität und der
Ästhetik. Ein Spiel des der Ungewöhnlichen und gleichzeitig so
Sinnvolles. Für alle, die zwei verschiedene Materialien auf eine
innovative Art und Weise verbinden möchten – eine neue zukünftige
Gestaltung. Ihrer Küche.

Kerrock et Inox. Unis dans une symbiose de fonctionnalité et
d'esthétisme. Un jeu insolite et pertinent à la fois. Pour ceux qui
souhaitent un entrecroisement innovant de deux matériaux.
Un entrecroisement pour former une nouvelle image de l'avenir.
Votre cuisine.

Actual dimensions may vary from stated ones (the plan). / Die angegebenen Dimensionen können (vom Entwurf) abweichen. / Les dimensions réelles peuvent différer (de celles du plan).

KERROCK&INOX KITCHEN SINKS / KERROCK&INOX
SPÜLBECKEN / KERROCK&INOX ÉVIERS DE CUISINE



142 ELLA 180

402 mm / 182 mm / 170 mm / Ø 90 mm

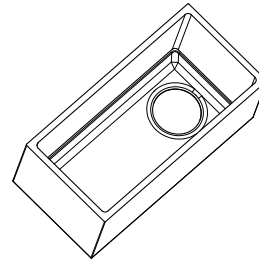
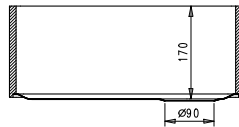
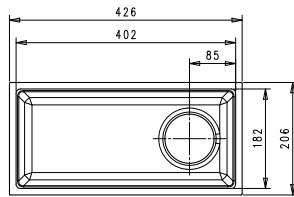

143 ELLA 340

402 mm / 342 mm / 170 mm / Ø 90 mm

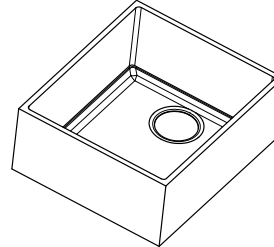
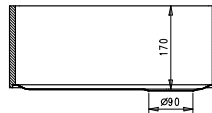
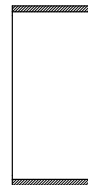
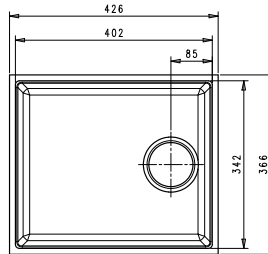

144 ELLA 400

402 mm / 402 mm / 170 mm / Ø 90 mm

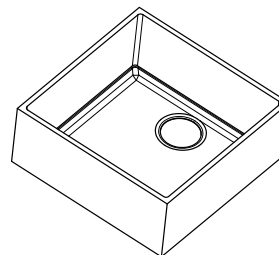
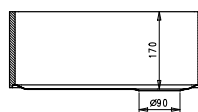
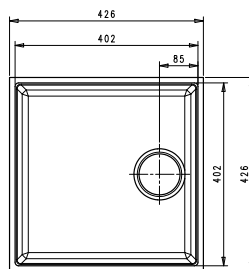

Legend: Washbasins available in unicolours, granite and teraco colours. / Legende: Der Waschbecken ist in Uni Colour Farben, Granit- sowie Teraco-Farben erhältlich. / Légende : Modèle disponible en coloris unis, granit et terraco.

SINKS FOR LABORATORIES AND MEDICINE

Washbasins whose speciality is ergonomic adaptability for the use in medicine and laboratories.

WASCHBECKEN FÜR LABORS UND MEDICINO

Eine Besonderheit der Waschbecken ist ergonomische Anpassung den medizinischen und Laborsbedürfnissen.

VASQUES POUR LES LABORATOIRES ET POUR LES MILIEUX MÉDICAUX

La caractéristique de ces vasques est la capacité d'adaptation ergonomique pour une utilisation en milieu médical et dans les laboratoires.



058 AVA

400 mm / 400 mm / 300 mm / Ø 90 mm

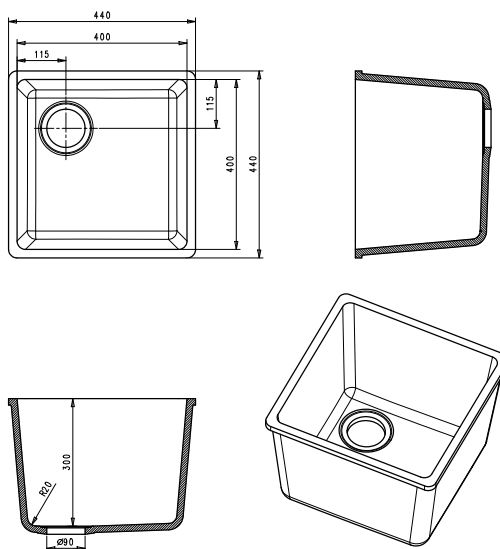

Actual dimensions may vary from stated ones (the plan). / Die angegebenen Dimensionen können vom Entwurf abweichen. / Les dimensions réelles peuvent différer (de celles du plan).

○ 108 Legend: This washbasin is available in unicolour 108. / Legende: Dieses Waschbecken ist nur in Uni Colour Farbe 108 erhältlich. / Légende : Modèle disponible uniquement en coloris unis 108.

SINKS FOR LABORATORIES AND MEDICINE /
 WASCHBECKEN FÜR LABORS UND MEDIZIN /
 VASQUES POUR LABORATOIRES ET POUR LES
 MILIEUX MÉDICAUX

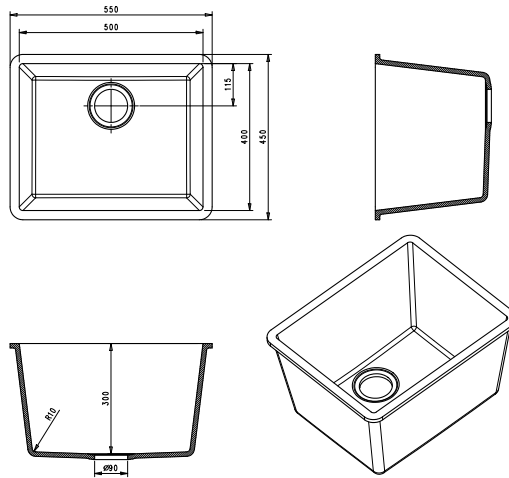

139 CARA

500 mm / 400 mm / 300 mm / Ø 90 mm

○ 108

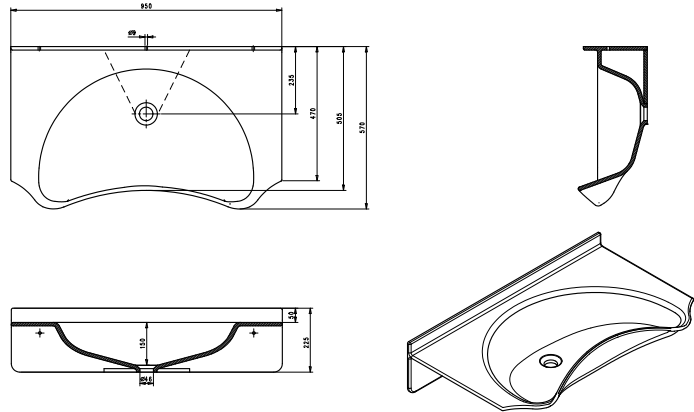

140 HIGIEA

950mm / 570 mm / 150 mm / Ø 46 mm

○ 108

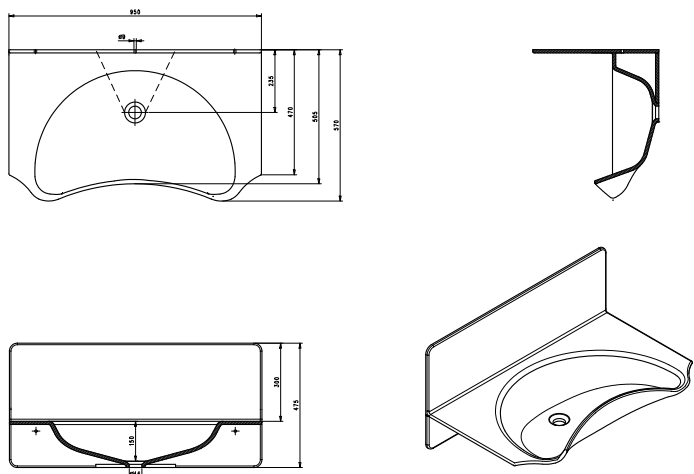

141 STERILIA

950mm / 570 mm / 150 mm / Ø 46 mm

○ 108

○ 108 Legend: This washbasin is available in unicolour 108. / Legende: Dieses Waschbecken ist nur in Uni Colour Farbe 108 erhältlich. /
 Légende : Modèle disponible uniquement en coloris unis 108.

UNIVERSAL SIPHONS / UNIVERSAL SIPHONS / SIPHONS UNIVERSELS

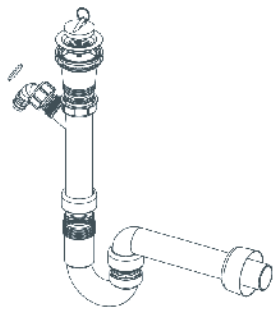

SIF-UM/46; id. 6510

Ø 46-siphon for the following washbasins / Siphon Ø 46 für
Washbecken / siphon Ø 46 pour les vasques

SILVIA, TINA, PETRA, TRU, SARA, BLANCA, LANA, EVA, MAJA,
IVA, ANA, RONDO, META, KERI, JANA, BARBI, AJDA, BEA, BRINA,
CHERI, KELI, LORA, VITA, IRIS, ROSA, BRINA VARIANT, CHERI
VARIANT, LORA VARIANT, ZENA 460, ZENA 600, OFELIA ON,
OFELIA IN, OFELIA UN, ORIANA ON, ORIANA IN, ORIANA UN,
OLIVIA ON, OLIVIA IN, OLIVIA UN, LINA, LUNA, HIGIEA, STERILIA

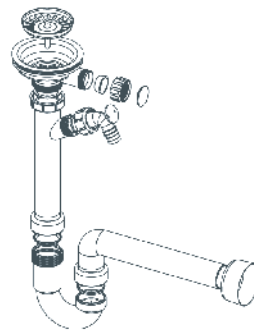

SIF-UM/90; id. 214640

Ø 90-siphon for the kitchen sink with or without the
overflow / Siphon Ø 90 für Spülbecken mit oder ohne
Überfluss / siphon Ø 90 pour les cuves avec ou sans trop-
plein

BETA, CORA, FLORA, ALYA, KHLOE, PIKA, ALITA, SONIA,
EMMA, NADIA, ELLA 180, ELLA 340, ELLA 400, AVA, CARA

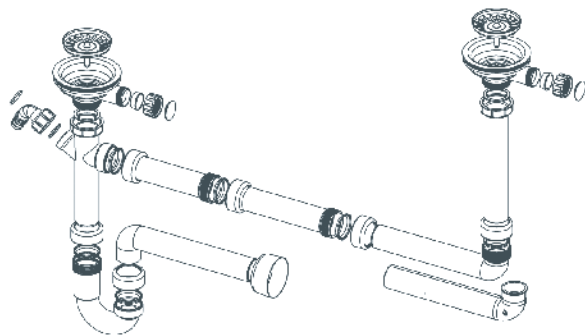

SIF-DV/90; id. 214650

Double Ø 90-siphon with connector / Doppelsiphon Ø 90
mit Anschluss / Siphon double Ø 90 avec raccordement

BINA, CARLA, HELEN and all combinations of 2 kitchen sinks.
Maximum distance between siphons is 550 mm. / BINA,
CARLA, HELEN und alle Kombinationen von 2 Spülbecken.
Max. Abstand zwischen den Siphons 550 mm. / BINA, CARLA,
HELEN et toutes les combinaisons de 2 cuves de cuisine. La
distance maximale entre les siphons est de 550 mm.

OUTFLOW VALVE for sinks with or
without overflow click-clack, Ø 45, chrome; id. 015372

AUSLAUFVENTIL für Spülbecken mit oder ohne Überfluss
click-clack, Ø 45, crom

VALVE D'ÉCOULEMENT pour vasques avec ou sans trop-
plein click-clack, Ø 45, chrome

SILVIA, TINA, PETRA, TRU, SARA, BLANCA, LANA, EVA, MAJA,
IVA, ANA, RONDO, META, KERI, JANA, BARBI, AJDA, BEA, BRINA,
CHERI, KELI, LORA, ZENA 460, ZENA 600, OFELIA ON, OFELIA
IN, OFELIA UN, ORIANA ON, ORIANA IN, ORIANA UN, OLIVIA ON,
OLIVIA IN, OLIVIA UN, LINA, LUNA, HIGIEA, STERILIA

SIPHONE CROM for outflow valve click-
clack, Ø 45, chrome; id. 015371

SIFON CROM für Auslaufventil click-clack, Ø 45, crom
SIPHON CHROME avec valve d'écoulement click-clack,
Ø 45, chrome

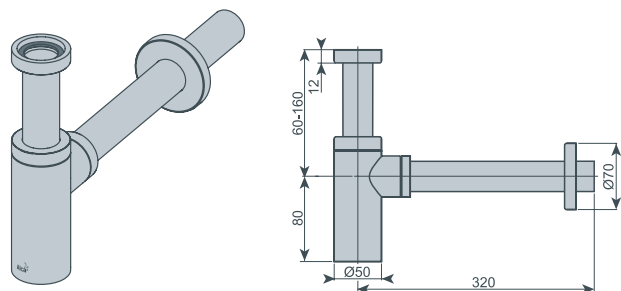
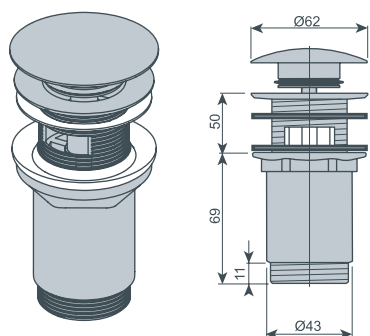

UNIVERSAL SIPHONS / UNIVERSAL SIPHONS / SIPHONS UNIVERSELS

OVERFLOW SET; id. 015360

ÜBERFLUSS-SET
SET TROP-PLEIN

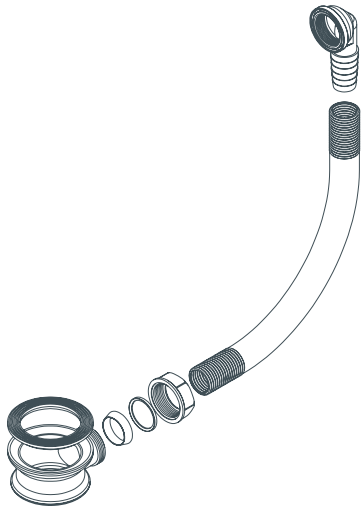

KERROCK COVER 108, FOR KERROCK WASHBASINS; id. 596600

KERROCK DECKEL 108, FÜR KERROCK WASHBECKEN
COUVERCLE KERROCK 108, POUR LES VASQUES KERROCK
VITA, IRIS, ROSA, BRINA VARIANT, CHERI VARIANT, LORA
VARIANT

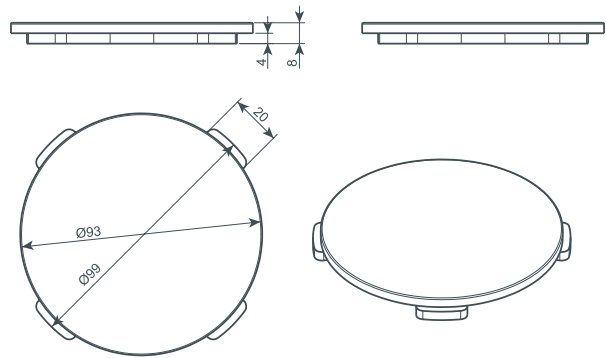

Ø 93 mm

○ 108

OVERFLOW FITTINGS; id. 210736

ÜBERLAUFGARNITUR
TROP-PLEIN POUR LES USTENSILES DE CUISINE

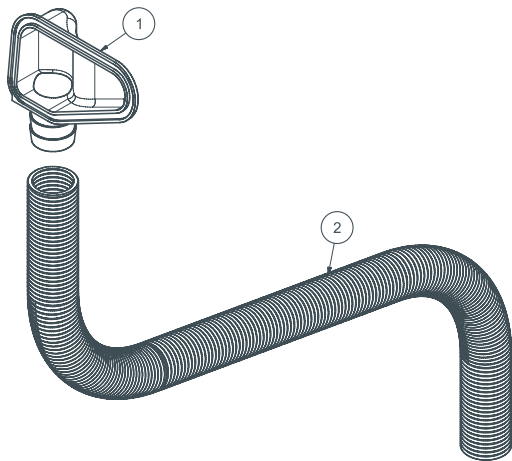

EASE OF CARE

It is for its simple cleaning and maintenance that Kerrock has become so popular; the stains can be removed by simply using water and ordinary cleaning agents. For a silky shine and freshness of colours we recommend cleaning by using fine abrasives.

PFLEGELEICHT

Durch seine einfache Wartung und Reinigung ist Kerrock so beliebt: alle Flecken können einfach mit Wasser und gewöhnlichen Reinigungsmitteln entfernt werden. Um den seidigen Glanz und Frische von Farben zu erhalten, empfehlen wir die Benutzung von feinen Schleifmitteln.

NETTOYAGE FACILE

Kerrock est réputé pour son nettoyage et son entretien faciles. On élimine aisément les tâches avec de l'eau et des produits de nettoyage courants. Pour conserver l'éclat soyeux et la fraîcheur des couleurs, nous recommandons un nettoyage avec des produits abrasifs fins.



KERIL

Special creamy abrasive cleaner

Special cleaner for Kerrock products, Kerrock surfaces and stainless steel.

Spezial creme Scheuermilch

Spezielles Putzmittel für Kerrock-Produkte, Kerrock-Flächen und rostfreien

Nettoyant abrasif crémeux special

Nettoyant spécial pour les produits Kerrock, les surfaces en Kerrock et en acier inoxydable.

KERROCK
PLATES
COLOUR
CHART:

KERROCK-PLATTEN
FARBKARTE:

GAMME DE
COULEURS DES
PANNEAUX KERROCK :



- >> UNI
- >> GRANIT
- >> TERRAZZO
- >> MIDNIGHT
BLACK
- >> METALIC
- >> EASY SHAPING
- >> KERROCK MF
- >> MARBLE
- >> LUMINO
- >> LUMINACO
- >> LUMINACO S

UNI

□ thickness & dimensions of sheets: see page 93 / Dicke und Dimensionen der Platten: siehe Seite 93 /
épaisseurs et dimensions des panneaux : voir page 93

			
arctic white 100    	polar white 101    	snow white 108    	white acrylic 109    
			
dusty white 117    	pearl white 118    	pineapple 213    	mustard 214   
			
cherry 400  	salmon 426    	crimson 427  	powder pink 428    
			
vanilla 500    	french vanilla 501    	bone 502    	bisque 503    
			
cream 506    	brown cream 509  	desert rose 512  	gray quartzite 513    

 suitable for claddings and surfaces not exposed to abrasion / geeignet für Verkleidungen und Oberflächen, die nicht zum Abrieb ausgesetzt sind / convient pour des revêtements et des surfaces non exposés à l'abrasion

 suitable for kitchen and other working surfaces / geeignet für Küche und andere Arbeitsoberflächen / convient pour des plans de cuisine et d'autres plans de travail

Colour hues shown in this catalogue may vary from the actual ones for printing reasons. Samples are displayed in the scale of 1:1. / Die in diesem Katalog gezeigten Farbtöne können sich druckbedingt von den tatsächlichen unterscheiden. Die Muster sind in der Skala 1:1 präsentiert. / Les couleurs présentées dans ce catalogue peuvent différer quelque peu des couleurs réelles en raison de l'impression. Les échantillons sont présentés à l'échelle de 1:1.

UNI

□ thickness & dimensions of sheets: see page 93 / Dicke und Dimensionen der Platten: siehe Seite 93 /
épaisseurs et dimensions des panneaux : voir page 93



sandstone
514    



lime
605    



shamrock
633  



oxygen blue
728    



adriatic blue
729   



dark navy
730 

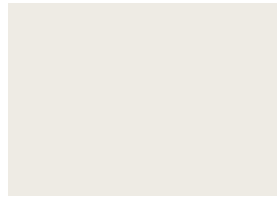

misty grey
900    



ash grey
901    

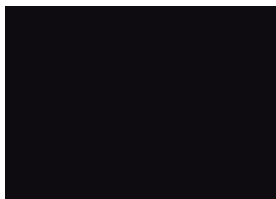

black
909  



gypsum
921    



water stone
922  



charcoal
923  

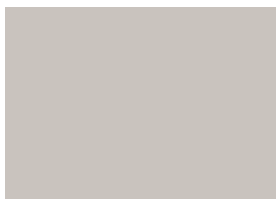

beigeing
924    



storm cloud
930   

 suitable for exterior use / geeignet für den Außenbereich / convient aux applications extérieures

 suitable for thermoforming / geeignet für Thermoforming / convient au thermoformage

Colour hues shown in this catalogue may vary from the actual ones for printing reasons. Samples are displayed in the scale of 1:1. / Die in diesem Katalog gezeigten Farbtöne können sich druckbedingt von den tatsächlichen unterscheiden. Die Muster sind in der Skala 1:1 präsentiert. / Les couleurs présentées dans ce catalogue peuvent différer quelque peu des couleurs réelles en raison de l'impression. Les échantillons sont présentés à l'échelle de 1:1.

GRANIT

□ thickness & dimensions of sheets: see page 93 / Dicke und Dimensionen der Platten: siehe Seite 93 /
épaisseurs et dimensions des panneaux : voir page 93



wollastonite
1076    



dolomite grain
1087    



iceland
1090    



salt and peper
1091    



hematite
1092    



pyrite
1093    



tourmaline
1099    



apenino
1193    



phenakite
5075    



desert gold
5080    



giadelite
5083    

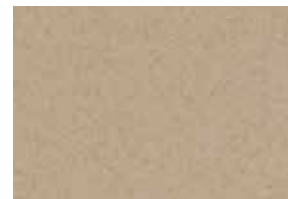

rhyolite
5194    



basalt
5195   

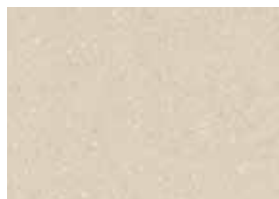

cryolite
5196    



hedenbergit
9011   

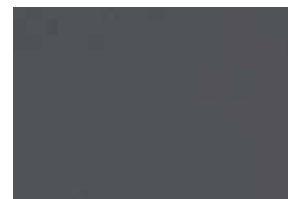

kyanite
9081  



leucite
9082    



molibdenite
9095  



onyx
9099  



manganite
9199    

 suitable for claddings and surfaces not exposed to abrasion / geeignet für Verkleidungen und Oberflächen, die nicht zum Abrieb ausgesetzt sind / convient pour des revêtements et des surfaces non exposés à l'abrasion

 suitable for kitchen and other working surfaces / geeignet für Küche und andere Arbeitsoberflächen / convient pour des plans de cuisine et d'autres plans de travail

Colour hues shown in this catalogue may vary from the actual ones for printing reasons. Samples are displayed in the scale of 1:1. / Die in diesem Katalog gezeigten Farbtöne können sich druckbedingt von den tatsächlichen unterscheiden. Die Muster sind in der Skala 1:1 präsentiert. / Les couleurs présentées dans ce catalogue peuvent différer quelque peu des couleurs réelles en raison de l'impression. Les échantillons sont présentés à l'échelle de 1:1.

TERRAZZO

□ thickness & dimensions of sheets: see page 93 / Dicke und Dimensionen der Platten: siehe Seite 93 /
épaisseurs et dimensions des panneaux : voir page 93



quartz
1050

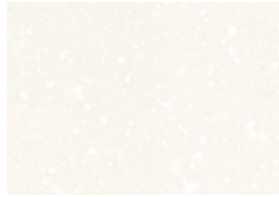

aragonite
1052

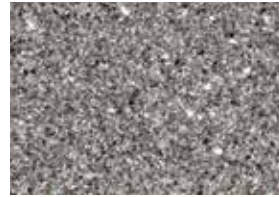

granulite
1055



sunrise terrazzo
1157

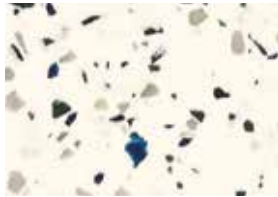

azzure terrazzo
1158

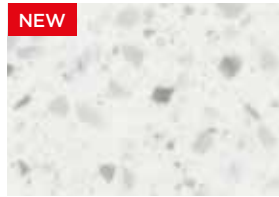

NEW
argento terrazzo
1159

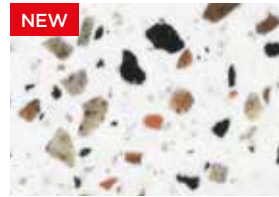

NEW
venetian terrazzo
1160



calcite
5053



albit
5061



semolina
5064



obsidian
9050



light concrete
9198



asphalt
9200

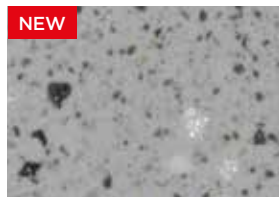

NEW
concrete terrazzo
9204

suitable for exterior use / geeignet für den Außenbereich / convient aux applications extérieures

suitable for thermoforming / geeignet für Thermoforming / convient au thermoformage

Colour hues shown in this catalogue may vary from the actual ones for printing reasons. Samples are displayed in the scale of 1:1. / Die in diesem Katalog gezeigten Farbtöne können sich druckbedingt von den tatsächlichen unterscheiden. Die Muster sind in der Skala 1:1 präsentiert. / Les couleurs présentées dans ce catalogue peuvent différer quelque peu des couleurs réelles en raison de l'impression. Les échantillons sont présentés à l'échelle de 1:1.

MIDNIGHT BLACK

- thickness & dimensions of sheets: see page 93 / Dicke und Dimensionen der Platten: siehe Seite 93 /
épaisseurs et dimensions des panneaux : voir page 93



nero
MB 990



bertanie
MB 9904

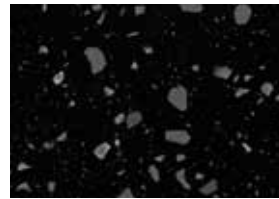

lavastone
MB 9955



cosmic
MB 9956



METALIC

- thickness & dimensions of sheets: see page 87 / Dicke und Dimensionen der Platten: siehe Seite 87 /
épaisseurs et dimensions des panneaux : voir page 87



platinum
1071*



white glitter
1194*



cocoa glitter
5170*



stardust
9017*



graphite
9070*



* featuring glitters / mit Glitzer / comprenant des paillettes

EASY SHAPING

KERROCK MF (MED CERTIFICATE)

- thickness & dimensions of sheets: see page 93 / Dicke und Dimensionen der Platten: siehe Seite 93 /
épaisseurs et dimensions des panneaux : voir page 93



kerrock es 112
ES 112



kerrock mf 178
MF 178



suitable for claddings and surfaces not exposed to abrasion / geeignet für Verkleidungen und Oberflächen, die nicht zum Abrieb ausgesetzt sind / convient pour des revêtements et des surfaces non exposés à l'abrasion



suitable for kitchen and other working surfaces / geeignet für Küche und andere Arbeitsoberflächen / convient pour des plans de cuisine et d'autres plans de travail

Colour hues shown in this catalogue may vary from the actual ones for printing reasons. Samples are displayed in the scale of 1:1. / Die in diesem Katalog gezeigten Farbtöne können sich druckbedingt von den tatsächlichen unterscheiden. Die Muster sind in der Skala 1:1 präsentiert. / Les couleurs présentées dans ce catalogue peuvent différer quelque peu des couleurs réelles en raison de l'impression. Les échantillons sont présentés à l'échelle de 1:1.

LUMINO

- thickness & dimensions of sheets: see page 93 / Dicke und Dimensionen der Platten: siehe Seite 93 /
épaisseurs et dimensions des panneaux : voir page 93

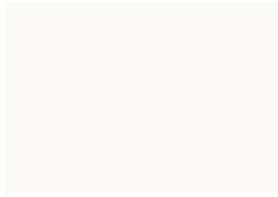

white
011



yellow
021

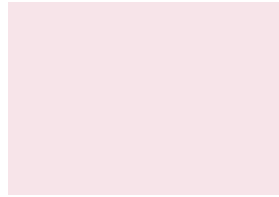

pink
041

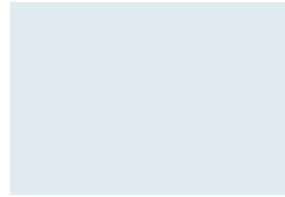

blue
071



LUMINACO

Original mix of Teraco Effect and translucent particles. / Originelle Mischung aus Teraco-Effekt und transluzenten Partikeln. / Mélange original de l'effet Teraco et de particules translucides.

- thickness & dimensions of sheets: see page 93 / Dicke und Dimensionen der Platten: siehe Seite 93 /
épaisseurs et dimensions des panneaux : voir page 93



strontianite
8101



colemanite
8501

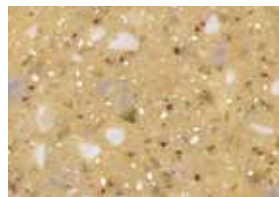

coral sand
8502



LUMINACO S

- thickness & dimensions of sheets: see page 93 / Dicke und Dimensionen der Platten: siehe Seite 93 /
épaisseurs et dimensions des panneaux : voir page 93



luxite
8102

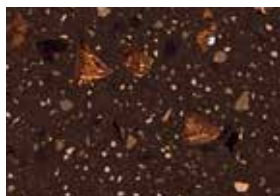

arkose
8503



opal brown
8901



🏠 suitable for exterior use / geeignet für den Außenbereich / convient aux applications extérieures

🍷 suitable for thermoforming / geeignet für Thermoforming / convient au thermoformage

Colour hues shown in this catalogue may vary from the actual ones for printing reasons. Samples are displayed in the scale of 1:1. / Die in diesem Katalog gezeigten Farbtöne können sich druckbedingt von den tatsächlichen unterscheiden. Die Muster sind in der Skala 1:1 präsentiert. / Les couleurs présentées dans ce catalogue peuvent différer quelque peu des couleurs réelles en raison de l'impression. Les échantillons sont présentés à l'échelle de 1:1.

- thickness & dimensions of sheets: see page 93 / Dicke und Dimensionen der Platten: siehe Seite 93 /
épaisseurs et dimensions des panneaux : voir page 93



buffalo
M 123



howlite
M 124



ivory brown
M 536



 suitable for claddings and surfaces not exposed to abrasion / geeignet für Verkleidungen und Oberflächen, die nicht zum Abrieb ausgesetzt sind / convient pour des revêtements et des surfaces non exposés à l'abrasion

 suitable for kitchen and other working surfaces / geeignet für Küche und andere Arbeitsoberflächen / convient pour des plans de cuisine et d'autres plans de travail

The spots on the plates are arranged randomly. Every plate is unique. / Die Flecken sind auf der Platte zufällig verteilt. Jede Platte ist ein Unikat. / Les motifs sur les plaques sont disposés de façon aléatoire. Chaque plaque est unique.

Colour hues shown in this catalogue may vary from the actual ones for printing reasons. Samples are displayed in the scale of 1:1. / Die in diesem Katalog gezeigten Farbtöne können sich druckbedingt von den tatsächlichen unterscheiden. Die Muster sind in der Skala 1:1 präsentiert. / Les couleurs présentées dans ce catalogue peuvent différer quelque peu des couleurs réelles en raison de l'impression. Les échantillons sont présentés à l'échelle de 1:1.

- thickness & dimensions of sheets: see page 93 / Dicke und Dimensionen der Platten: siehe Seite 93 /
épaisseurs et dimensions des panneaux : voir page 93



diaspore
M 1060



alabaster
M 1156



barite
M 5079



suitable for exterior use / geeignet für den Außenbereich / convient aux applications extérieures

suitable for thermoforming / geeignet für Thermoforming / convient au thermoformage

The spots on the plates are arranged randomly. Every plate is unique. / Die Flecken sind auf der Platte zufällig verteilt. Jede Platte ist ein Unikat. / Les motifs sur les plaques sont disposés de façon aléatoire. Chaque plaque est unique.

Colour hues shown in this catalogue may vary from the actual ones for printing reasons. Samples are displayed in the scale of 1:1. / Die in diesem Katalog gezeigten Farbtöne können sich druckbedingt von den tatsächlichen unterscheiden. Die Muster sind in der Skala 1:1 präsentiert. / Les couleurs présentées dans ce catalogue peuvent différer quelque peu des couleurs réelles en raison de l'impression. Les échantillons sont présentés à l'échelle de 1:1.

- thickness & dimensions of sheets: see page 93 / Dicke und Dimensionen der Platten: siehe Seite 93 /
épaisseurs et dimensions des panneaux : voir page 93



staurolite
M 5155



gabbro
M 9078



pyroxene
M 9197



 suitable for claddings and surfaces not exposed to abrasion / geeignet für Verkleidungen und Oberflächen, die nicht zum Abrieb ausgesetzt sind / convient pour des revêtements et des surfaces non exposés à l'abrasion

 suitable for kitchen and other working surfaces / geeignet für Küche und andere Arbeitsoberflächen / convient pour des plans de cuisine et d'autres plans de travail

The spots on the plates are arranged randomly. Every plate is unique. / Die Flecken sind auf der Platte zufällig verteilt. Jede Platte ist ein Unikat. / Les motifs sur les plaques sont disposés de façon aléatoire. Chaque plaque est unique.

Colour hues shown in this catalogue may vary from the actual ones for printing reasons. Samples are displayed in the scale of 1:1. / Die in diesem Katalog gezeigten Farbtöne können sich druckbedingt von den tatsächlichen unterscheiden. Die Muster sind in der Skala 1:1 präsentiert. / Les couleurs présentées dans ce catalogue peuvent différer quelque peu des couleurs réelles en raison de l'impression. Les échantillons sont présentés à l'échelle de 1:1.

- thickness & dimensions of sheets: see page 93 / Dicke und Dimensionen der Platten: siehe Seite 93 /
épaisseurs et dimensions des panneaux : voir page 93

NEW

OUR LEED
CERTIFICATE PROVES
WE ARE ECOLOGICAL.

By using Kerrock in various projects, you are choosing an environmentally friendly product. It does not contain any VOC (volatile organic compounds) and is suitable for contact with food.

MIT DEM LEED-
ZERTIFIKAT BEWEISEN
WIR, DASS WIR
ÖKOLOGISCH SIND.

Durch die Verwendung von Kerrock in verschiedenen Projekten wählen Sie ein umweltfreundliches Produkt. Es enthält keine flüchtigen organischen Verbindungen (VOC) und ist für den Kontakt mit Lebensmittel geeignet.

AVEC LA CERTIFICATION
LEED, NOUS PROUVONS
QUE NOUS SOMMES
ÉCOLOGIQUES.

En utilisant Kerrock dans divers projets, vous choisissez un produit respectueux de l'environnement. Il ne contient aucun COV (composés organiques volatils) et convient au contact avec les aliments.



pantheon
M 9202



 suitable for exterior use / geeignet für den Außenbereich / convient aux applications extérieures

 suitable for thermoforming / geeignet für Thermoforming / convient au thermoformage

The spots on the plates are arranged randomly. Every plate is unique. / Die Flecken sind auf der Platte zufällig verteilt. Jede Platte ist ein Unikat. / Les motifs sur les plaques sont disposés de façon aléatoire. Chaque plaque est unique.

Colour hues shown in this catalogue may vary from the actual ones for printing reasons. Samples are displayed in the scale of 1:1. / Die in diesem Katalog gezeigten Farbtöne können sich druckbedingt von den tatsächlichen unterscheiden. Die Muster sind in der Skala 1:1 präsentiert. / Les couleurs présentées dans ce catalogue peuvent différer quelque peu des couleurs réelles en raison de l'impression. Les échantillons sont présentés à l'échelle de 1:1.

property / Eigenschaft / propriétés	value / Wert / valeur	method / methode / méthode
VOLUME MASS / RAUMGEWICHT / MASSE VOLUMIQUE	1680–1750 kg/m ³	SIST EN ISO 1183-1 method A / SIST EN ISO 1183-1 Methode A / SIST EN ISO 1183-1 méthode A
DISTORTION MODULE / BIEGEMODUL / MODULE DE FLEXION	8800–9800 Mpa	SIST EN ISO 178
DISTORTION STRENGTH / BIEGEFESTIGKEIT / RÉSISTANCE À LA FLEXION	50–71 Mpa	SIST EN ISO 178
TENSILE STRENGTH / ZUGFESTIGKEIT / RÉSISTANCE À LA TRACTION	29–53 Mpa	SIST EN ISO 527-1
ELONGATION AT BREAK / REISSDEHNUNG / ALLONGEMENT A LA RUPTURE	0,50–0,90 %	SIST EN ISO 527-1
IMPACT STRENGTH (Charpy) / SCHLAGFESTIGKEIT (Charpy) / LA RÉSISTANCE AU CHOC (Charpy)	3,0–5,5 kJ/m ²	SIST EN ISO 179-1
HARDNESS (according to Barcol) / HÄRTE (nach Barcol) / DURETE (Barcol)	58–64	SIST EN 59
LINEAR COEFFICIENT OF EXPANSION / LINEARE DEHNUNGSZAHL / COEFFICIENT DE DILATATION LINÉAIRE	3,7 x 10 ⁻⁵ K ⁻¹	α (-20 °C - +50 °C)
WATER ABSORPTION (after 24 hours) / WASSERAUFNAHME (nach 24 Stunden) / ABSORPTION DE L'EAU (après 24 heures)	0,03 %	SIST EN ISO 62 method 1 / SIST EN ISO 62 Methode 1 / SIST EN ISO 62 Méthode 1
RESISTANCE TO STEAM EFFECTS (1 hour) / DAMPFBESTÄNDIGKEIT (1 Stunde) / RÉSISTANCE À LA VAPEUR (1 heure)	degree 4 – slight change in shine, only visible under certain angles / Klasse 4 – geringe Glanzveränderung, sichtbar unter einem bestimmten Sichtwinkel / niveau 4 – legere altération de la surface, visible seulement sous certains angles de vue	SIST EN 438-2
RESISTANCE TO HOT CONTAINER EFFECTS / BESTÄNDIGKEIT GEGEN HEISSES GESCHIRR / RÉSISTANCE AUX FONDS DE CASSEROLES CHAUD	degree 4 – slight change in shine, only visible under certain angles / Klasse 4 – geringe Glanzveränderung, sichtbar unter einem bestimmten Sichtwinkel / niveau 4 – legere altération de la surface, visible seulement sous certains angles de vue	SIST EN 438-2
RESISTANCE TO BURNING CIGARETTE EFFECTS / BESTÄNDIGKEIT GEGEN BRENNENDE ZIGARETTEN / RÉSISTANCE À LA BRÛLURE DE CIGARETTE	degree 4 – slight change in shine, only visible under certain angles / Klasse 4 – geringe Glanzveränderung, sichtbar nur unter einem bestimmten Sichtwinkel / niveau 4 – légère altération de la surface, visible seulement sous certains angles de vue	SIST EN 438-2
RESISTANCE TO ATMOSPHERIC AGENTS / BESTÄNDIGKEIT GEGEN ATMOSPHÄRIEN / RÉSISTANCE AUX AGENTS ATMOSPHÉRIQUES	No changes / keine Veränderung / aucune modification	Exposed outdoors for 2 years / 2 Jahre draußen ausgesetzt / expose 2 ans à l'extérieur
CLASSIFICATION OF MATERIAL RESPONSE TO FIRE / KLASSIFIKATION DES MATERIALS IM BRANDFALL / CLASSEMENT DE LA REACTION AU FEU DU MATERIAU	B- s1, d0	SIST EN 13501-1
SURFACE RESISTANCE / OBERFLÄCHENWIDERSTAND / RÉSISTANCE SUPERFICIELLE	2,0 x 10 ¹¹ – 2,0 x 10 ¹² Ω	DIN VDE 0303-3 IEC 93
SPECIFIC PENETRATION RESISTANCE / SPEZIFISCHER DURCHGANGSWIDERSTAND / RÉSISTANCE À LA PÉNÉTRATION SPÉCIFIQUE	7,9 x 10 ¹³ – 1,2 x 10 ¹⁴ Ω cm	DIN VDE 0303-3 IEC 93
AVALANCHE CURRENT RESISTANCE / BESTÄNDIGKEIT GEGEN KRIECHSTRÖME / RÉSISTANCE AU COURANT AVALANCHE	CTI 600 M	DIN VDE 0303-1 IEC 112
RELATIVE DIELECTRIC CONSTANT (Er) / RELATIVE DIELEKTRIZITÄTSZAHL (Er) / CONSTANCE DIELECTRIQUE RELATIVE (Er)	4,5	DIN VDE 0303-4 IEC 250
DIELECTRIC LOSS FACTOR tg at MHz / FAKTOR DIELEKTRISCHER VERLUSTE tg bei MHz / FACTEUR DE PERTES DIÉLECTRIQUES tg à MHz	2,8 x 10 ⁻³	DIN VDE 0303-4 IEC 250
MEDICAL INTEGRITY / GESUNDHEITLICHE UNBEDENKLICHKEIT / HYGIENE	suits / entspricht / correspond à	Article 3 of the Regulation of the European Parliament and of the EC Council no. 1935/2004 on materials and articles intended to come into contact with foodstuffs. / Artikel 3 der Verordnung des Europäischen Parlaments und Rates (EU) Nr. 1935/2004 über Materiale und Erzeugnisse, die für den Kontakt mit Nahrungsmitteln bestimmt sind. / l'article 3 du règlement du Parlement et du Conseil européens (CE) n ° 1935/2004 sur les matériaux et les objets destinés à entrer en contact avec des denrées alimentaires

Data is not valid for plates ES and MF. / Die Angaben gelten nicht für Platten ES und MF. / Ces informations ne s'appliquent pas aux plaques ES et MF.

01

3600 x 760 mm (2,74 m²)

thickness of sheets Dicke der Platten épaisseur des panneaux	UNI	GRANIT	TERRAZZO	MIDNIGHT BLACK	METALIC	EASY SHAPING	KERROCK MF	LUMINO	LUMINACO	LUMINACOS	MARBLE
3 mm	•	-	-	-	-	-	-	-	-	-	-
6 mm	•	•	-	-	•	-	-	•	-	-	-
8 mm	•	•	•*	-	•	-	-	•	-	-	-
12 mm	•	•	•	•	•	•	•	•	•	•	•
18 mm	•	•	•	-	-	-	-	-	-	-	-

* only for colours / nur für Farben / uniquement pour les couleurs: 1050, 1052, 5053

02

3600 x 910 mm (3,28 m²)*

thickness of sheets Dicke der Platten épaisseur des panneaux	UNI	GRANIT	TERRAZZO	MIDNIGHT BLACK	METALIC	EASY SHAPING	KERROCK MF	LUMINO	LUMINACO	LUMINACOS	MARBLE
6 mm	•	-	-	-	-	-	-	-	-	-	-

* Standard production colours of plates are 100 and 108. Other colours as per order. / Standardgemäß werden die Platten in Farbe 100 und 108 produziert. Sonstige Farben nach Bestellung. / Les plaques standards sont réalisées en couleurs 100 et 108. Les autres couleurs s'obtiennent sur commande.

03

3600 x 930 mm (3,35 m²)*

thickness of sheets Dicke der Platten épaisseur des panneaux	UNI	GRANIT	TERRAZZO	MIDNIGHT BLACK	METALIC	EASY SHAPING	KERROCK MF	LUMINO	LUMINACO	LUMINACOS	MARBLE
12 mm	•	-	-	-	-	-	-	-	-	-	-

* Standard production colours of plates are 100 and 108. Other colours as per order. / Standardgemäß werden die Platten in Farbe 100 und 108 produziert. Sonstige Farben nach Bestellung. / Les plaques standards sont réalisées en couleurs 100 et 108. Les autres couleurs s'obtiennent sur commande.

04

3600 x 1350 mm (4,86 m²)

thickness of sheets Dicke der Platten épaisseur des panneaux	UNI	GRANIT	TERRAZZO	MIDNIGHT BLACK	METALIC	EASY SHAPING	KERROCK MF	LUMINO	LUMINACO	LUMINACOS	MARBLE
6 mm	•	•	-	-	•	-	-	-	-	-	-
8 mm	•	•	-	-	•	-	-	-	-	-	-
12 mm	•	•	•*	-	•	-	-	-	-	-	-

* except the colours / außer den Farben / sauf les couleurs: 1157, 1158, 1159, 1160,

Panels of different sizes are not of the same batch, therefore deviation in shade is possible. / Die Platten unterschiedlicher Dimensionen haben nicht die selbe Charge, deshalb können sie verschiedene Farbtöne haben. / Les panneaux de différentes dimensions n'appartiennent au même lot, donc ils peuvent varier en tonalité.

REFERENCES / REFERENZEN / RÉFÉRENCE

HOTELS / HOTELS / HÔTELS

furniture equipment for rooms, equipment for bathrooms, furniture equipment for common spaces / Möbelausstattung für Zimmer, Ausstattung für Badezimmer, Möbelausstattung für gemeinsame Räumlichkeiten / l'équipement mobilier des chambres, l'équipement de salles de bains, l'équipement mobilier des espaces communs

- >> Hotel Alhambra 5* Lošinj, Croatia
- >> Hotel Marriot 5* Saudi Arabia
- >> Hotel Belvue Lošinj 5*, Croatia
- >> Hotel Libertas Dubrovnik 5* Croatia
- >> Hotel Bellvue Dubrovnik 5* Croatia
- >> Hotel Slovenia Portorož 5*, Slovenia
- >> Hotel Balnea Terme Krka 4 *sup, Slovenia
- >> Star wood hotel Aloft 4 Riyadh, Saudi Arabia
- >> Star wood hotel Aloft 4 Dhahran, Saudi Arabia
- >> Hotel Lav 4*, Split, Croatia
- >> Terme 3000 Moravske Toplice 4*, Slovenia
- >> Hotel Aparthotel Hintertux 4*, Austria
- >> Hotel and villas Royal 4*, Opatija, Croatia
- >> Thermal complex Rimske terme 4* Slovenia
- >> Terme Tuhelj 4*, Croatia
- >> Hotel Punta and Vespera 4* Lošinj, Croatia
- >> Tourist resort Solaris Šibenik 4*, Croatia
- >> Terme Krka Strunjan 4*; Slovenia
- >> Hotel Park Bled 4*, Slovenia
- >> Hotel Krka Novo mesto 4*, Slovenia
- >> Grand Hotel Atlantik Opatija 4*, Croatia
- >> Hotel Golf 4*, Bled, Slovenia
- >> Hotel Agava Opatija 4*, Croatia
- >> Hotel Sotelia Podčetrtek 4*, Slovenia
- >> Hotel Laguna Albatros Poreč 4, Croatia
- >> Hotel Valamar Zagreb 4*, Poreč, Croatia
- >> Hotel Lučica Brač 4*, Croatia
- >> Hotel Sol Garden Umag 4*, Croatia
- >> Hotel Meteor Makarska 4*, Croatia
- >> Hotel Park Makarska 4, Croatia
- >> Luna Island Hotel 4*, Pag, Croatia
- >> Hotel Kristal Dolenjske toplice 4*, Slovenia
- >> Hotel Sol Umag 4*, Croatia



REFERENCES / REFERENZEN / RÉFÉRENCE

WELLNESS

- >> Terme 3000, Moravske Toplice, Slovenia
- >> Wellness hotel Rivera, Portorož, Slovenia
- >> Swimming pool Kolezija, Ljubljana, Slovenia
- >> Wellness hotel Bellvue, Mali Lošinj, Croatia
- >> Swimming pool Koper, Koper, Slovenia,
- >> Wellness hotel Punta, Mali Lošinj, Croatia
- >> Wellness Rimske Terme, Rimske Toplice, Slovenia



MEDICINE / MEDIZIN / MEDECINE

- >> Sankt Gertrauden Hospital Berlin, Germany
- >> Emergency Center Novo mesto, Slovenia
- >> Emergency Center Brezice, Slovenia
- >> Emergency Center Celje, Slovenia
- >> Emergency Center Izola, Slovenia
- >> General Hospital Novo mesto, Slovenia
- >> General Hospital Slovenj Gradec, Slovenia
- >> Institute of Oncology Ljubljana, Slovenia
- >> Health Center Slovenska Bistrica, Slovenia
- >> Pharmacy Duplek Maribor, Slovenia
- >> Clinical Center Split, Croatia
- >> GKB 24, Twentyfourth City hospital, Russia
- >> Central Clinical hospital of Federal custom service, Russia
- >> Clinical department of Russian medicine scientific Academy, Russia
- >> Federal National Institute, Russia
- >> Celjske lekarne, Pharmacy Rogaška, Slovenia
- >> Ljubljanske lekarne, Pharmacy Škofljica, Slovenia
- >> Pharmacy Slavonski Brod, Croatia,
- >> Health Center Novo mesto, Slovenia,
- >> University Medical Centre Ljubljana, Department of Haematology, Slovenia
- >> Dental Center Čelesnik, Bled, Slovenia



REFERENCES / REFERENZEN / RÉFÉRENCE

RETAIL / EINZELHANDEL / VENTE AU DÉTAIL

- >> Nakhell mall Riyadh, Saudi Arabia
- >> Yasmin mall Jedda, Saudi Arabia
- >> Hamra mall Riyadh, Saudi Arabia
- >> Telekom store, Pogačarjev trg, Ljubljana, Slovenia
- >> Dyson – Oxford Street, London
Project Name: Dyson Experience Store – London
Designers: Dyson
Photographer: N/A
- >> Ludlow Thompson – Canada Water, East Dulwich & Clapham Road
Project Name: Roll-out of new store design & brand identity
Designers: Battistini Augustus
Photographer: Award Photography
- >> KitchenAid – Wigmore Street, London
Project Name: KitchenAid Experience Store – London
Designers: Concept: Maestria. Detailed Design: Battistini Augustus
Photographer: Award Photography
- >> JEM Urbanwear, Konstanz Germany
Project Name: JEM Urbanwear, Konstanz Germany
Designers: Studio DLF
Photographer: Daniele Luciano Ferrazzano
- >> Overkill women, Berlin Kreuzberg
Project Name: Overkill women, Berlin Kreuzberg
Designers: Studio DLF / plus 4930
Photographer: Overkill
- >> Tuš Planet, Koper, Slovenia
- >> Tuš shopping center, Rijeka, Croatia
- >> Tuš Planet, Novo mesto, Slovenia



REFERENCES / REFERENZEN / RÉFÉRENCE

PUBLIC AND BUINESS SPACES / ÖFFENTLICHE UND
GESCHÄFTLICHE RÄUME / ESPACES PUBLICS ET COMMERCIAUX

- >> Krka, NOTOL 2, galery, Slovenia
- >> Nova TV, Zagreb, Croatia
- >> Gospodarsko razstavišče, Ljubljana
Exhibition and Convention Centre
Ljubljana, Slovenia
- >> Primary school Litija, Litija, Slovenia
- >> Airport dr. Franjo Tuđman Zagreb,
Zagreb, Croatia
- >> Mobitel Ljubljana, Ljubljana, Slovenia
- >> Energetika Ljubljana, Slovenia
- >> BHRC – Heathrow Terminal 2
Project Name: Arrivals Hall desk location
Designers: Battistini Augustus
Photographer: Award Photography
- >> BHRC – St Pancras
Project Name: Island desk
Designers: Battistini Augustus
Photographer: Award Photography
- >> Stationery Oxford center Ljubljana,
Slovenia
- >> Havenhuis Antwerpen
GF design
Photographer: Hendrik Biëgs
- >> Tunnel in Denmark/Kolding
Architechts: Kollision
The Fabricator: Boye Inventar
- >> Aarhus Festival (Column in the river)
Architechts: Kollision aarhus
The Fabricators: Boye Inventar
- >> Roskilde Library
Architechts: Kollision Aarhus
Manufactor: Boye Inventar
- >> Bird observation point, Škocjanski zatok,
Slovenia
- >> Medicoengineering d.o.o., Trzin,
Ljubljana, Slovenia
- >> Eles Ljubljana, Ljubljana, Slovenia,
- >> Helios Domžale, Slovenia
- >> Cultural and Congress Center Dolenjske
Toplice, Slovenia



RESIDENTAL / RESIDENZ / RÉSIDENCE

- >> Kitchen
Designers: GERD COUCKHUYT
The Fabricator: VDB PRODUCTIONS
- >> Bathroom
Project Name: FlatForm
Designers: Desnahemisfera
- >> Kitchen
Project Name: Kitchen Twist
Designers: Matejca Cukala u.d.i.a + Petra Kuštrin abs. arch
- >> House Jožica Brodarič, Metlika, Slovenia
- >> Mizarstvo Hip, Joinery workshop, Janko Kukec, s. p.





kolpa
Since
1978

KOLPA, d.d. Metlika
Rosalnice 5
8330 Metlika, Slovenija
Tel: + 386 7 36 92 100
Faks: + 386 7 36 92 166
www.kolpa.si

SALES: | VERTRIEB: | VENTE:

Pod Barončevim hribom 4
8000 Novo mesto, Slovenija | Slowenien | Slovénie
Phone: | Tel.: | Tel.: + 386 7 393 33 00
Fax: + 386 7 393 33 50
E-mail: | E-mail: | Courriel: info@kolpa.si



www.kerrock.eu

kerrock[®]
by KOLPA